

(19) 日本国特許庁 (J P)

(12) 公開特許公報 (A)

(11) 特許出願公開番号

特開2000-107870

(P2000-107870A)

(43) 公開日 平成12年4月18日 (2000.4.18)

(51) Int.Cl. ⁷	識別記号	F I	テマート [*] (参考)
B 2 3 K 20/00	3 1 0	B 2 3 K 20/00	3 1 0 L 3 H 0 1 3
B 2 1 D 41/02		B 2 1 D 41/02	D 4 E 0 6 7
B 2 3 K 9/028		B 2 3 K 9/028	B 4 E 0 8 1
F 1 6 L 13/02		F 1 6 L 13/02	
15/00		15/00	

審査請求 未請求 請求項の数 9 O L (全 25 頁) 最終頁に続く

(21) 出願番号 特願平10-286403

(22) 出願日 平成10年10月8日 (1998.10.8)

(71) 出願人 000003713

大同特殊鋼株式会社

愛知県名古屋市中区錦一丁目11番18号

(72) 発明者 冷水 孝夫

愛知県名古屋市中区表山二丁目311番地

八幸サンハイツ501

(72) 発明者 堀尾 浩次

愛知県東海市加木屋町南鹿持18 大同特殊

鋼知多寮C-317

(72) 発明者 鬼頭 一成

愛知県名古屋市長区古鳴海二丁目38番地

(74) 代理人 100095869

弁理士 上野 登 (外1名)

最終頁に続く

(54) 【発明の名称】 拡管用金属管接合体及びその製造方法

(57) 【要約】

【課題】 拡管した場合であっても、接合部の強度及び気密性が低下することがなく、また、拡管する際の変形抵抗が少なく、しかも、接合部に発生する段差を小さくすることができる拡管用金属管接合体及びその製造方法を提供すること。

【解決手段】 端部拡径率が5%以上となるように端部近傍の内径が拡径された金属管30同士を拡散接合又は溶接し、あるいは端部近傍の内径が拡径されていない金属管50を所定の横断出率となるように拡散接合することにより、接合部の内径が非接合部の内径より大きくなっている金属管接合体32、52を得る。また、端部拡径率が10%以上となるように端部近傍の内径が拡径された金属管40同士を機械的に締結することにより、接合部の内径が非接合部の内径より大きくなっている金属管接合体42を得る。

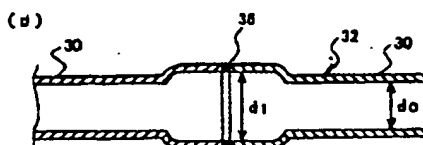
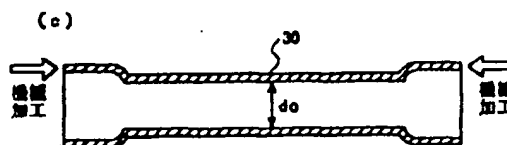
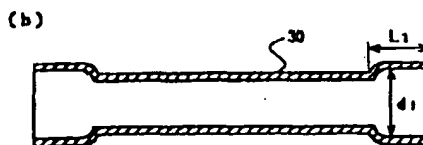

【特許請求の範囲】

【請求項1】 複数の金属管が接合された金属管接合体であって、接合部の内径が、非接合部の内径より大きいことを特徴とする拡管用金属管接合体。

【請求項2】 金属管の端部近傍の内径を拡径し、該金属管同士を接合することを特徴とする拡管用金属管接合体の製造方法。

【請求項3】 端部拡径率が5%以上となるように、前記金属管の端部近傍の内径を拡径することを特徴とする請求項2に記載の拡管用金属管接合体の製造方法。

【請求項4】 接合方法が拡散接合法であることを特徴とする請求項2又は3に記載の拡管用金属管接合体の製造方法。

【請求項5】 接合方法がアーク溶接法であることを特徴とする請求項2又は3に記載の拡管用金属管接合体の製造方法。

【請求項6】 金属管の端部近傍の内径を拡径し、該金属管の端部にねじを形成し、該ねじにより前記金属管同士を機械的に締結することを特徴とする拡管用金属管接合体の製造方法。

【請求項7】 端部拡径率が10%以上となるように、前記金属管の端部近傍の内径を拡径することを特徴とする請求項6に記載の拡管用金属管接合体の製造方法。

【請求項8】 端部近傍の内径が拡径されていない金属管を突き合わせ、接合部近傍が横膨出するような接合条件で拡散接合することを特徴とする拡管用金属管接合体の製造方法。

【請求項9】 接合部近傍の横膨出率が1.04以上となるように拡散接合することを特徴とする請求項8に記載の拡管用金属管接合体。

【発明の詳細な説明】

【0001】

【発明の属する技術分野】本発明は、拡管用金属管接合体及びその製造方法に関し、更に詳しくは、化学工業、石油化学工業等で用いられるプラント用配管、ラインパイプ、あるいは油井で用いられるケーシングチューブ、生産チューブ、コイルドチューブ等の油井管として好適な拡管用金属管接合体及びその製造方法に関するものである。

【0002】

【従来の技術】従来から、化学工業、石油化学工業等の分野においては、腐食性の流体を長距離に亘って輸送するために、長尺の金属管が使用されている。例えば、パイプラインは、油田から得られた原油等を精油所等に輸送するためのものであり、その長さは数十kmに及ぶ。

【0003】また、油井を掘削するに際しては、地中に掘削された坑道の保護や原油の漏出防止等のために、坑道の中にケーシングと呼ばれる鋼管が埋設される。油田は、通常、地下数千mの位置にあるので、ケーシングも数千mの長さを有するものが必要とされる。

【0004】一方、腐食環境に曝される金属管には、耐食性に優れた継目無鋼管が一般に用いられるが、工業的に量産されている継目無鋼管の長さは、10~15mであり、製造可能な長さの上限は100m程度である。従って、ラインパイプ、あるいはケーシング等の油井管には、長さ10~15mの継目無鋼管を複数個接続した接合体が用いられている。

【0005】このような用途に用いられる金属管の接合方法としては、ねじ接続法（メカニカルカップリング法）、溶接法（オービタルウェルディング法）、拡散接合法などが知られている。

【0006】また、所定の長さを有する金属管が複数個接合された接合体（以下、これを「金属管接合体」という）は、内径を拡大あるいは縮小させることなくそのまま使用されるのが一般的である。すなわち、所望の内径を有する金属管接合体は、所望の内径を有する金属管を接合することにより製造されるのが一般的である。

【0007】しかしながら、地上に敷設されるラインパイプ等と異なり、油井に用いられるケーシング等は、地中に埋設されるものであるため、所定の内径を有する金属管接合体をそのままケーシング等として使用すると以下のような問題がある。

【0008】すなわち、地下数千mの位置にある油田に向かって裸坑のまま坑道を掘り進むのは困難である。そのため、油井の掘削作業は、先端にビットが取り付けられたドリルパイプを用いて坑道を掘削する作業と、ある程度掘り進んだところで、坑道を保護するためにケーシングを埋設する作業と、埋設されたケーシングと地層の間にセメントを流し込み、ケーシングを固定する作業とが順次繰り返される。その結果、油井は、複数のケーシングが入れ子状に重なった構造となる。

【0009】図8に油井の一般的な構造を示す。図8に例示する油井10は、地表付近の坑壁を保護するための最大外径を有するコンダクターパイプ12と、コンダクターパイプ12の中に順次入れ子状に挿入される、サーフェスケーシング14、中間ケーシング16、及び油層20まで達する最長の生産ケーシング18の4つのケーシングを備えている。

【0010】しかしながら、先に埋設されたケーシング（以下、これを「外側ケーシング」という）の中央の穴を通して、次のケーシング（以下、これを「内側ケーシング」という）を坑道内に埋設する際、内側ケーシングと外側ケーシングの軸がずれていたり、あるいは内側ケーシング又は外側ケーシングのいずれか一方の形状が不規則になっていると、内側ケーシングの挿入が困難になる場合がある。そのため、内側ケーシングの外径は、余裕を見込んで、外側ケーシングの内径より10~30%程度小さくする必要があった。

【0011】また、油井の生産能率は、油層に達する生産ケーシングの内径に依存する。従って、所定の生産能

10

20

30

40

50

率を確保するためには、生産ケーシングの内径を所定の大きさとするのみならず、先に埋設されるケーシングの内径も大きくする必要があり、そのため、地表付近に掘削される坑道の内径を大きくする必要が生じ、油井掘削コストを増大させる原因となっていた。

【0012】そこで、この問題を解決するために、特表平7-507610号公報には、地中に掘削されたボアホールに可鍛材料製ケーシングを埋設し、液圧膨張ツールをケーシング内で膨張させることにより、ケーシングをボアホール壁に対して半径方向に膨張させる方法が開示されている。

【0013】また、特許協力条約に基づく国際公開第W098/0062号には、ネッキングや延性破壊することなく歪硬化を生ずる可鍛性の鋼種からなる鋼管を坑道、あるいは先に埋設されたケーシング内に挿入し、非金属材料からなるテーパ面を有するマンドレルを用いてケーシングを拡張する方法が開示されている。

【0014】特表平7-507610号公報あるいは国際公開第W098/0062号に開示された方法によれば、坑道あるいは外側ケーシングの内径に比して、相対的に小さな外径を有する内側ケーシングを挿入することができるので、内側ケーシングの挿入作業を円滑に行うことができるという利点がある。

【0015】また、液圧膨張ツール又はマンドレルを用いて、坑道あるいは外側ケーシングに挿入された内側ケーシングの拡張が行われるので、坑道の断面積のほぼ全部を原油輸送に使用できるという利点がある。また、坑道の有効断面積が大きくなることにより、掘削すべき坑道の内径を小さくすることができ、掘削コストを削減できるという利点がある。

【0016】さらに、特表平7-507610号公報に開示されているように、ケーシングをボアホール壁に対して半径方向に膨張させた場合には、ボアホール壁から受ける圧縮応力によりケーシングが保持されるので、セメンティング作業が不要になるという利点がある。

【0017】

【発明が解決しようとする課題】しかしながら、油井に用いられるケーシングは、全長が数千mに達するものであり、接合部が必ず存在するにもかかわらず、特表平7-507610号公報あるいは国際公開第W098/0062号に開示されている方法においては、接合部が全く考慮されていない。

【0018】例えば、金属管を溶接法、あるいは拡散接合法等の冶金的接合法により接合して金属管接合体とした場合には、接合部近傍は、接合時の加熱により熱影響部が発生し、変形能が低下していることがある。そのため、得られた金属管接合体をそのままマンドレル等を用いて拡張した場合には、接合部に亀裂が発生するおそれがあるという問題がある。

【0019】また、例えば、金属管をねじ接続法により

接合して金属管接合体とし、これをマンドレル等を用いて拡張した場合には、拡張時の塑性変形によってねじの部分に凹み、接合部の気密性が低下するという問題がある。

【0020】さらに、ねじ接続法は、図7に示すように、通常、金属管1、2の端部に外ねじ1a、2bを形成し、その外ねじ1a、2bと螺合可能な内ねじ7aを有する継手7を介して、金属管1、2が接合される。従って、接合部近傍は、非接合部に比して厚肉となるので、このような金属管接合体をマンドレル等を用いて拡張した場合には、接合部の変形抵抗が大きくなり、拡張作業を円滑に行うことができないという問題がある。

【0021】また、マンドレルを用いて、同一内径を有する長さ数千mの金属管接合体を一気に拡張する場合、マンドレルは、拡張時に金属管接合体から絶えず反力を受け続けるので、マンドレルを移動させるのに大きな動力が必要となる。

【0022】この問題を解決するために、例えば、国際公開第W098/0062号には、マンドレルのテーパ面をジルコニア等の非金属材料で構成することにより、マンドレルとケーシング間に発生する摩擦力を低減する点が開示されているが、拡張中にマンドレルが絶えずケーシングから一定の反力を受け続ける点に変わりはなく、省動力化という点では不十分である。

【0023】一方、特表平7-507610号公報に開示されているように、液圧膨張ツールをケーシング内のある位置に保持し、液圧膨張ツールを膨張させてその位置にあるケーシングのみを拡張し、次いで液圧膨張ツールを収縮させた後に上方に移動させるというプロセスを繰り返せば、マンドレルを用いて一気に拡張する場合に比して省動力化することができる。しかしながら、ケーシングを段階的に拡張することになるので作業能率が悪いという欠点がある。

【0024】さらに、拡散接合法を用いて金属管を接合する場合、金属管は、端面のみを平坦に加工し、外周面及び肉厚の修正をすることなく、そのまま接合に用いるのが一般的である。一方、工業的に量産される金属管には、所定の寸法公差があり、各金属管の外径及び肉厚は、寸法公差の範囲内ではばらついている。

【0025】そのため、量産された金属管をそのまま用いて拡散接合した場合には、得られる金属管接合体の接合部に段差が発生するおそれがある。接合部に発生した段差には、応力が集中しやすいので、このような金属管接合体を拡張した場合には、段差部分から亀裂が発生するおそれがある。また、拡張後も接合部に段差が残るために、応力集中や、段差部分に腐食性物質が滞留することに起因して、強度、疲労特性及び耐食性が低下するおそれがある。しかしながら、このような問題を解決する具体的手段についても、上述した先行技術文献には、何ら開示されていない。

10

20

30

40

50

【0026】本発明が解決しようとする課題は、拡管を行っても接合部に亀裂が発生したり、ねじの緩みに起因する接合部の気密性の低下が生ずることのない拡管用金属管接合体及びその製造方法を提供することにある。

【0027】また、本発明が解決しようとする他の課題は、拡管する際の変形抵抗が小さく、しかも拡管作業の省動力化が可能な拡管用金属管接合体及びその製造方法を提供することにある。

【0028】さらに、本発明が解決しようとする他の課題は、接合部に発生する段差が小さく、しかも強度、疲労特性及び耐食性に優れた拡管用金属管接合体及びその製造方法を提供することにある。

【0029】

【課題を解決するための手段】上記課題を解決するために、本発明に係る拡管用金属管接合体は、複数の金属管が接合された金属管接合体であって、接合部の内径が、非接合部の内径より大きいことを要旨とするものである。

【0030】このような拡管用金属管接合体は、具体的には、予め金属管の端部近傍の内径を拡径し、該金属管同士を接合することにより容易に製造することができる。この場合、端部拡径率が5%以上となるように、前記金属管の端部近傍の内径を拡径することが望ましい。端部拡径率が5%未満になると、拡管を行う際に、接合部から亀裂が発生するおそれがあるので好ましくない。また、この場合、接合方法としては、拡散接合法又はアーク溶接法が好適である。

【0031】また、上述のような拡管用金属管接合体は、金属管の端部近傍の内径を拡径し、該金属管の端部にねじを形成し、該ねじにより前記金属管同士を機械的に締結することによっても製造することができる。この場合、端部拡径率が10%以上となるように、前記金属管の端部近傍の内径を拡径することが望ましい。端部拡径率が10%未満になると、拡管を行ったときにねじ部が塑性変形し、ねじ部の気密性が低下するので好ましくない。

【0032】さらに、上述のような拡管用金属管接合体は、端部近傍の内径が拡径されていない金属管を突き合わせ、接合部近傍が横彫出するような接合条件で拡散接合することによっても製造することができる。この場合、接合部近傍の横彫出率が1.04以上となるように拡散接合することが望ましい。横彫出率が1.04未満になると、拡管を行う際に、接合部から亀裂が発生するおそれがあるので好ましくない。

【0033】上記構成を有する本発明に係る拡管用金属管接合体は、接合部の内径が非接合部の内径より大きくなっているため、このような拡管用金属管接合体を、マンドレル等を用いて拡管した場合には、接合部の塑性歪を、非接合部の塑性歪より小さく抑えることができる。

【0034】そのため、例えば、端部内径が予め所定の

端部拡径率で拡径された金属管を拡散接合法又は溶接法で接合し、得られた金属管接合体を拡管した場合において、接合界面近傍に熱影響部が発生し、接合界面近傍の変形能が低下している場合であっても、拡管により接合部に亀裂が発生しにくくなる。

【0035】また、端部内径が拡径されていない金属管を突き合わせ、拡散接合時の加圧力により、接合部を所定の横彫出率で樽型に塑性変形させて金属管接合体とし、これを拡管した場合には、接合部における亀裂の発生が抑制されるだけでなく、金属管の端部内径を拡径する工程が不要となるという利点がある。

【0036】さらに、端部内径が所定の端部拡径率で拡径された金属管をねじ接合法により接合して金属管接合体とした場合において、拡管率が前記端部拡径率以下となるように前記金属管接合体を拡管した場合には、接合部が塑性変形することがない。そのため、ねじの弛みに起因する気密性の低下が生じない。

【0037】また、本発明に係る拡管用金属管接合体は、接合部近傍の内径が、非接合部の内径より大きくなっているため、接合部近傍における変形抵抗が小さくなる。そのため、拡管作業を円滑に行うことができ、しかも拡管作業の省動力化も図られる。

【0038】さらに、金属管の端部を予め所定の端部拡径率で拡径し、拡径された金属管を接合して金属管接合体とした場合には、拡径により少なくとも各金属管の内径を揃えることができる。そのため、外径あるいは肉厚が所定の寸法公差内でばらついている金属管を用いて金属管接合体を作製した場合であっても、接合部の内周面側に発生する段差を小さくすることができ、強度、疲労特性、及び耐食性に優れた金属管接合体を得ることが可能となる。

【0039】

【発明の実施の形態】以下に、本発明の実施の形態について図面を参照しながら詳細に説明する。図1は、本発明の第1の実施の形態に係る拡管用金属管接合体の製造方法（以下、これを「方法A」という）を示す工程図である。図1において、方法Aは、拡径工程と、端面加工工程と、拡散接合工程とを備えている。

【0040】まず、拡径工程について説明する。拡径工程は、図1(a)に示すような、円筒状の金属管30の内、両端の内径のみを適当な工具等を用いて拡大させ、図1(b)に示すように、端部の内径 d_1 が中央部の内径 d_2 より大きくなっている金属管30に加工する工程である。

【0041】ここで、本発明に用いられる金属管30は、後述する拡管に耐える変形能を有する材料であれば良く、その材質、寸法等については、特に限定されるものではない。例えば、機械的特性のみが要求される用途に用いられる金属管接合体にあっては、金属管30として炭素鋼を用いることができる。また、例えば、ライン

パイプ、油井管等、強度と耐食性の双方が要求される用途にあっては、マルテンサイト系ステンレス鋼、二相ステンレス鋼、オーステナイト系ステンレス鋼等のステンレス鋼、Ti合金等を用いることができる。

【0042】また、本発明においては、各金属管30の拡張前の内径の最小値に対する、拡張後の金属管30の内径の増分を端部拡張率と呼び、次の数1の式で定義する。

【0043】

$$\text{【数1】 端部拡張率 (\%) = (d_1 - d_{\min}) \times 100 / d_{\min} \quad 10$$

但し、 d_1 : 金属管30端部の拡張後の内径

d_{\min} : 金属管30端部の拡張前の内径の最小値

【0044】方法Aの場合、端部拡張率は、5%以上が望ましい。端部拡張率が5%未満であると、後述する拡張工程において、接合部を大きく塑性変形させる必要が生じ、接合部に亀裂が発生するおそれがあるので好ましくない。また、端部拡張率が5%未満であると、各金属管30の寸法精度によっては、接合部に大きな段差が発生し、疲労強度が低下する場合があるので好ましくない。

【0045】これは、金属管30の内径が所定の寸法公差内ではらつている場合において、端部拡張率が5%未満になると、拡張前の内径 d_0 が、拡張後の内径 d_1 より小さい金属管のみが拡張されるようになり、 d_1 より大きい内径を有する金属管が拡張されないおそれがあるためである。

【0046】なお、端部拡張率の計算に用いられる内径の最小値 d_{\min} としては、安全率を見込むという点では、接合に用いられる金属管の規格から予測される最小値を用いることが望ましいが、実測値を用いても良い。

【0047】また、端部拡張率は、接合部の塑性変形を小さくし、亀裂の発生を抑制するという点では、大きい程良い。従って、金属管30の加工の容易性、得られる金属管接合体の用途等に応じて、後述する拡張率以下の範囲内において、最適な端部拡張率で拡張を行えばよい。

【0048】また、拡張により内径が拡大した部分の長さ(以下、これを「拡張長さ」といい、図1(b)中、「L」で表示。)は、金属管30の加工の容易性、用途等を考慮して任意に選択すればよいが、後述する拡張工程における変形抵抗を小さくし、拡張作業の省動力化を図るという点では、長い程良い。

【0049】さらに、拡張方法も、特に限定されるものではなく、種々の方法を用いることができる。通常は、数1の式に示す d_1 に相当する外径を有するマンドレルあるいはプラグ等を、所定の長さだけ、金属管30の端部に挿入し、端部内径を拡張すればよい。

【0050】次に、端面加工工程について説明する。端

面加工工程は、図1(c)に示すように、拡張工程により端部内径が拡張された金属管30の端面を所定の表面粗さに機械加工する工程である。これは、金属管30の端面の表面粗さが粗いと、後述する拡散接合工程において、接合界面が十分に密着せず、高い接合強度が得られないためである。

【0051】なお、端面の加工方法は、特に限定されるものではなく、研削加工、ラッピング加工等、各種の方法を用いることができる。また、拡張後も金属管30の端面の表面粗さが所定の範囲に維持されている場合には、端面加工工程は必ずしも必要ではなく、省略することもできる。

【0052】次に、拡散接合工程について説明する。拡散接合工程は、拡張工程において端部内径が拡張され、さらに端面加工工程において、端面が所定の表面粗さに加工された金属管30を突き合わせ、金属管30、30同士を拡散接合させる工程である。

【0053】ここで、拡散接合法には、金属管30を直接突き合わせ、固相状態を維持しながら元素の拡散を行わせる固相拡散接合と、接合界面にインサート材を介挿し、インサート材を一時的に融解させながら元素の拡散を行わせる液相拡散接合とがあるが、いずれの方法を用いてもよい。

【0054】特に、液相拡散接合は、固相拡散接合に比して、短時間で母材と同等の強度を有する接合体が得られるので、接合方法として好適である。図1(d)に、金属管30、30の接合界面にインサート材36を介挿し、液相拡散接合法により接合された金属管接合体32の一例を示す。

【0055】また、拡散接合の条件は、使用する金属管30の材質に応じて最適な範囲を選択すればよい。具体的には、以下の条件下で行うとよい。

【0056】まず、接合面の表面粗さ R_{max} は、50 μm 以下が好ましい。接合面の表面粗さ R_{max} が50 μm を超えると、接合面において金属管30同士が十分に密着せず、高い接合強度が得られないので好ましくない。高い接合強度を得るという点では、表面粗さ R_{max} は小さい程良い。

【0057】また、使用するインサート材36は、融点が1200 $^{\circ}\text{C}$ 以下であるNi系合金又はFe系合金が好適である。インサート材36の融点が1200 $^{\circ}\text{C}$ を超えると、高い接合温度が必要となるので、接合中に母材を溶融させたり、あるいはインサート材36の未溶融に起因する未接合部が発生するので好ましくない。

【0058】また、使用するインサート材36の厚さは、100 μm 以下が好ましい。インサート材36の厚さが100 μm を超えると、接合界面における元素の拡散が十分に行われず、接合強度が低下するので好ましくない。

【0059】なお、インサート材36の形状は、特に限

定されるものではなく、厚さ100μm以下の箔状のインサート材36を接合界面に介挿してもよく、あるいは、厚さが100μm以下となるように、粉末状もしくは鱗片状のインサート材36を接合界面に散布したり、ペースト状にして接合界面に塗布してもよい。

【0060】接合雰囲気は、非酸化性雰囲気が好ましい。酸化性雰囲気下で拡散接合を行うと、接合界面近傍が酸化し、接合強度が低下するので好ましくない。

【0061】接合温度は、1250℃以上1400℃以下の範囲が好適である。接合温度が1250℃未満になると、インサート材36が部分的に溶融しなかったり、あるいは元素の拡散が十分に行われず、接合強度が低下するので好ましくない。また、接合温度が1400℃を超えると、母材が溶融するおそれがあるので好ましくない。

【0062】接合温度における保持時間は、30秒以上300秒以下が好適である。保持時間が30秒未満であると、接合界面における元素の拡散が不十分となり、接合強度が低下するので好ましくない。また、保持時間が300秒を超えると、作業効率が低下するので好ましくない。

【0063】さらに、接合界面に付与する加圧力は、1.5MPa以上5MPa以下が好適である。加圧力が1.5MPa未満であると、接合界面の密着が不十分となり、接合強度が低下するので好ましくない。

【0064】また、方法Aにおいては、金属管を接合した後、後述する拡管工程において金属管接合体の拡管を行うので、接合後に接合部近傍が若干変形していてもよい。但し、拡管工程における内径の増分と、接合時の変形に起因する内径の増分の総和が、後述する拡管工程における拡管率を超えると、拡管後も接合界面近傍に凹凸が残り、接合強度を低下させる原因となる。従って、方法Aにおいては、接合部近傍が過大に変形しないよう、加圧力は、5MPa以下とするのが好ましい。

【0065】また、拡散接合を行う際の加熱方法としては、高周波誘導加熱、高周波直接通電加熱、抵抗加熱等の各種の方法を用いることができる。中でも高周波誘導加熱及び高周波直接通電加熱は、比較的大きな被接合材であっても容易に加熱でき、加熱効率が高く、極めて短時間に接合温度まで加熱できるので、加熱方法として特に好適である。

【0066】ただし、高周波誘導加熱又は高周波直接通電加熱に用いる高周波電流としては、周波数が100kHz以下のものを用いるのが好ましい。周波数が100kHzを超えると、表皮効果により表面のみが加熱され、接合面全面が均一に加熱されないのが好ましくない。

【0067】次に、このようにして得られた拡管用金属管接合体の拡管工程について説明する。拡管工程は、上述した拡径工程、端面加工工程及び拡散接合工程におい

て製造された金属管接合体32の拡管を行い、金属管接合体32の内径を一様の大径にする工程である。

【0068】具体的には、図2(a)に示すように、接合部及び非接合部の内径が、それぞれ d_1 及び d_0 である金属管接合体32の一端からマンドレル34を挿入し、図2(b)に示すように、金属管接合体32の他端に向かってマンドレル34を移動させ、金属管接合体32の内径を d_2 まで拡大させればよい。本発明においては、拡管前の非接合部の内径の最小値に対する拡管後の内径の増分を拡管率と呼び、次の数2の式で定義する。

【0069】
 【数2】拡管率(%) = $(d_2 - d_{0min}) \times 100 / d_{0min}$

但し、 d_2 ; 拡管後の非接合部の内径
 d_{0min} ; 拡管前の非接合部の内径の最小値

【0070】なお、方法Aの場合、拡管率は、金属管30の変形能や、金属管接合体32の用途等を考慮して、任意に選択すればよい。また、接合条件が適切であれば、接合部近傍の変形能を高く維持することができるので、端部拡径率よりも大きな拡管率で拡管することもできる。さらに、拡管前の非接合部の内径の最小値 d_{0min} として、規格から予測される最小値を用いても良く、実測値を用いても良い点は、数1の式と同様である。

【0071】次に、方法Aの作用について説明する。所定の長さ及び内径を有する金属管30(図1(a))の端部を、所定の端部拡径率及び所定の拡径長さ L_1 で拡径し(図1(b))し、端面を所定の表面粗さに機械加工した後(図1(c))、金属管30同士を拡散接合すると、図1(d)に示すように、接合部の内径 d_1 が非接合部の内径 d_0 より大きくなっている金属管接合体32を得ることができる。

【0072】このような金属管接合体32の一端にマンドレル34を挿入し、他端に向かってマンドレル34を移動させると、金属管接合体32の内径が拡大し、図2(b)に示すように、一定の内径 d_2 を有する金属管接合体32を得ることができる。

【0073】この時、拡管前の接合部の内径 d_1 は、非接合部の内径 d_0 より大きくなっているため、拡管時における接合部の塑性歪は、非接合部の塑性歪より小さくなる。そのため、拡散接合の際に熱影響部が発生し、接合部の変形能が低下している場合であっても、拡管により接合部に亀裂が発生しにくくなる。

【0074】また、接合部の内径 d_1 が非接合部の内径 d_0 より大きいため、接合部近傍の変形抵抗が小さくなる。この変形抵抗の減少量は、接合部の内径 d_1 が大きくなるほど、あるいは拡径長さ L_1 が長くなるほど、大きくなる。そのため、拡管の際にマンドレル34が受ける摩擦抵抗の総和は、一様な内径を有する金属管接合体を拡管する場合に比較して小さくなり、拡管作業の省

10

20

30

40

50

動力化が図られる。

【0075】さらに、各金属管30の外径及び肉厚が寸法公差内でばらついている場合であっても、金属管30の端部近傍の内径を拡張し、各金属管30の内径を揃えた後に接合すれば、金属管接合体32の接合部の内周面側に発生する段差を小さくすることができる。そのため、このような金属管接合体32は、拡張を行っても、接合部から段差に起因する亀裂が発生するおそれが少ない。また、応力集中や、腐食物質の滞留が起りにくくなるので、拡張された金属管接合体32の強度、疲労特性及び耐食性が低下することもない。

【0076】なお、上述の方法Aにおいては、接合法として拡散接合法を用いているが、接合法として、アーケ溶接法を用いても良く、これにより同様の効果を得ることができる(以下、これを「方法A'」という)。この場合、拡張工程において、金属管30の端部近傍の内径を所定の端部拡張率で拡張し、端面加工工程において金属管30の端面に開先を形成し、これを突き合わせて開先に溶融金属を肉盛りすればよい。

【0077】次に、本発明の第2の実施の形態に係る拡張用金属管接合体の製造方法について説明する。図3は、本発明の第2の実施の形態に係る拡張用金属管接合体の製造方法(以下、これを「方法B」という)を示す工程図である。図3において、方法Bは、拡張工程と、ねじ加工工程と、締結工程とを備えている。

【0078】拡張工程は、上述した方法Aと同様に、図3(a)に示すような、円筒状の金属管40の内、端部近傍の内径のみを適当な工具等を用いて拡大させることにより、図3(b)に示すように、端部近傍の内径が所定の端部拡張率で拡張された金属管40に加工する工程である。

【0079】但し、方法Bの場合、端部拡張率は、10%以上が望ましい。端部拡張率が10%未満であると、後述する拡張工程において、接合部を大きく塑性変形させる必要が生じるが、ねじ接続法により締結された接合部を塑性変形させると、ねじが弛み、気密性が低下するので好ましくない。

【0080】なお、金属管40として拡張に耐える変形能を有するあらゆる材料を用いることができる点、拡張長さL₁は金属管40の加工の容易性等を考慮して任意に選択すればよい点、及び拡張方法として種々の方法を用いることができる点は、上述した方法Aと同様である。

【0081】次に、ねじ加工工程においては、図3(c)に示すように、拡張工程により端部内径が拡張された金属管40の端部に外ねじ40aが形成される。なお、ねじ接続法の場合、接合部で支えることができる荷重はねじの長さL₂に依存するので、ねじの長さL₂は、金属管接合体42に要求される特性に応じて、任意に定めることができる。

【0082】次に、締結工程においては、拡張工程において端部内径が拡張され、さらにねじ加工工程において、端部に外ねじ40aが形成された金属管40同士が、継手44を介して、締結される工程である。継手44には、金属管40に形成された外ねじ40aと螺合可能な内ねじ44aが形成されている。このようにして得られた金属管接合体42を図3(d)に示す。

【0083】製造された金属管接合体42は、方法Aにより得られた金属管接合体32と同様に、拡張が行われ、金属管接合体42の内径が一樣の大きさd₂に拡大される。具体的には、図4(a)に示すように、金属管接合体42の一端からマンドレル34を挿入し、図4(b)に示すように、金属管接合体42の他端に向かってマンドレル34を移動させることにより、金属管接合体42の内径を所定の拡張率で拡張させる。

【0084】ここで、方法Bの場合、金属管接合体42の拡張は、金属管40の端部拡張率以下の拡張率で行うことが望ましい。拡張率が端部拡張率を超えると、拡張時に接合部が塑性変形し、ねじが緩むおそれがあるので好ましくない。また、接合部近傍は、継手44があるために肉厚となっている。そのため、端部拡張率を超える拡張率で拡張するのは、変形抵抗の増大を招き、円滑な拡張作業が困難となるので好ましくない。

【0085】次に、方法Bの作用について説明する。予め端部拡張率が10%以上となるように、金属管40の端部近傍の内径を拡張し、金属管40同士をねじ接続法により接合すると、接合部の内径d₁が非接合部の内径d₂より大きくなっている金属管接合体42を容易に得ることができる。

【0086】このようにして得られた金属管接合体42を、マンドレル等を用いて拡張すれば、方法Aと同様に、接合部近傍の変形抵抗が小さくなる。そのため、均一な内径を有する金属管接合体を拡張する場合に比して、拡張作業の省動力化が図られる。しかも、端部拡張率以下の拡張率で拡張が行われるので、ねじの塑性変形に起因する気密性の低下という、ねじ接続法特有の問題も解決される。

【0087】次に、本発明の第3の実施の形態に係る拡張用金属管接合体の製造方法について説明する。図5(a)~(c)は、本発明の第3の実施の形態に係る拡張用金属管接合体の製造方法(以下、これを「方法C」という)を示す工程図である。

【0088】方法Cの場合、金属管50として、拡張に耐える変形能を有するあらゆる材料を用いることができる点は、方法Aと同様であるが、円筒状の金属管50の端部を拡張することなく、そのまま拡散接合を行い、拡散接合の際に、接合部近傍を樽型に変形させる点が異なっている。

【0089】すなわち、図5(a)に示すような円筒状の金属管50の端部を拡張することなく、そのまま突き

合わせて加圧し(図5(b))、熱源54を介して接合部近傍を加熱する。なお、接合方法は、図5(b)に示すように、接合界面にインサート材36を介挿させて接合を行う液相拡散接合法でも良く、あるいはインサート材36を用いない固相拡散接合を用いてもよい。

【0090】この時、接合条件が適切であると、接合界面において拡散接合が進行すると同時に、接合界面近傍が樽型に変形し、図5(c)に示すように、接合部の内径 d_1 が非接合部の内径 d_0 より大きくなっている金属管接合体52を得ることができる。本発明においては、非接合部の金属管の内径の最小値に対する、拡散接合後の接合部の内径の増分を横膨出率と呼び、次の数3の式で定義する。

【0091】

〔数3〕横膨出率 $= d_1 / d_0 \dots$

但し、 d_1 : 接合部の内径

$d_0 \dots$: 非接合部の内径の最小値

【0092】方法Cの場合、横膨出率は、1.04以上が望ましい。横膨出率が1.04未満であると、後述する拡管工程において、接合部を大きく塑性変形させる必要が生じ、接合部に亀裂が発生するおそれがあるので好ましくない。

【0093】なお、非接合部の内径の最小値 $d_0 \dots$ として、規格から予測される最小値を用いても良く、実測値を用いても良い点は、数1の式と同様である。また、横膨出率は、拡管時における接合部の塑性歪を小さくし、亀裂の発生を抑制するという点では、大きい程良い。さらに、拡散接合により内径が増加した部分の長さ(以下、これを「膨出長さ」といい、図5(c)中、「L₁」で表示。)は、拡管工程における変形抵抗を小さくするという点では、長い程良い。

【0094】また、方法Cの場合、拡散接合時に接合界面近傍を積極的に塑性変形させる必要があるため、拡散接合の条件も、要求される横膨出率等が得られる条件を選択する必要がある。具体的には、以下の条件下で接合するとよい。

【0095】すなわち、接合温度は、1250℃以上1400℃以下の範囲が好適である。接合温度が1250℃未満になると、インサート材が部分的に溶融しなかったり、あるいは元素の拡散が十分に行われず、接合強度が低下するおそれがある。また、接合温度が低すぎると、金属管50の変形抵抗が大きくなり、所定の横膨出率が得られないので好ましくない。さらに、接合温度が1400℃を超えると、母材が溶融するおそれがあるので好ましくない。

【0096】接合温度における保持時間は、60秒以上が好適である。保持時間が60秒未満であると、大きな横膨出率を得ることができないので好ましくない。なお、横膨出率を大きくするという点では、保持時間は長い程良いので、所望の横膨出率が得られるように、保

持時間を調節するとよい。

【0097】また、接合界面に付与する加圧力は、2MPa以上が好適である。加圧力が2MPa未満であると、大きな横膨出率を得ることができないので、好ましくない。なお、方法Cの場合、横膨出率を大きくするという点では、加圧力は大きい程良く、5MPa以上であっても良い。但し、横膨出率が拡管率を超えると、拡管後も、接合界面近傍に凹凸が残り、接合強度が低下する。従って、加圧力は、横膨出率が拡管率以下となるように調節することが望ましい。

【0098】さらに、接合部近傍の加熱幅は、20mm以上が好適である。加熱幅が20mm未満になると、横膨出率が小さくなると共に、膨出長さ L_1 も短くなるので好ましくない。拡管時の変形抵抗をより小さくするという点では、横膨出率が大きく、かつ膨出長さ L_1 も長い方が良く、そのためには、加熱幅は長い方がよい。

【0099】なお、接合面の表面粗さ R_{max} は、50 μ m以下が好ましい点、使用するインサート材は、融点が1200℃以下である厚さ100 μ m以下のNi系合金又はFe系合金が好ましい点、インサート材の形状は、特に限定されるものではなく、箔状、粉末状あるいは鱗片状のインサート材を用いることができる点は、方法Aと同様である。

【0100】また、接合雰囲気は、非酸化性雰囲気为好ましい点、及び拡散接合を行う際の熱源としては、周波数100kHz以下の高周波電流を用いた高周波誘導加熱、又は高周波直接通電加熱为好ましい点も、方法Aと同様である。

【0101】次に、上述のようにして製造された所定の横膨出率を有する金属管接合体52の拡管が行われる。具体的には、図5(d)に示すように、金属管接合体52の一端からマンドレル34を挿入し、金属管接合体52の他端に向かってマンドレル34を移動させればよい。

【0102】なお、拡管率は、金属管50の変形能や、金属管接合体52の用途等を考慮して、任意に選択すればよい点、及び、接合条件が適切であれば、接合部近傍の変形能を高く維持することができるので、端部拡管率よりも大きな拡管率で拡管することもできる点は、方法Aと同様である。

【0103】次に、方法Cの作用について説明する。端部内径が拡径されていない金属管50を突き合わせ、金属管50同士を拡散接合すると同時に、接合部近傍を積極的に塑性変形させると、接合部の内径 d_1 が非接合部の内径 d_0 より大きくなっている金属管接合体52を容易に得ることができる。

【0104】このようにして得られた金属管接合体52を、マンドレル等を用いて拡管すれば、方法Aと同様に、接合部近傍の変形抵抗が小さくなる。そのため、均一な内径を有する金属管接合体を拡管する場合に比し

て、拡管作業を円滑に行うことができ、拡管作業の省動力化も図られる。

【0105】また、接合部の内径が大きくなっていることにより、拡管時における接合部の塑性歪を小さくすることができる。そのため、方法Aと同様に、接合部近傍に熱影響部が発生し、変形能が低下している場合であっても、拡管により接合部に亀裂が発生しにくくなり、強度及び気密性に優れた金属管接合体を得ることができる。

【0106】(実施例1)方法Aを用いて、金属管接合体の拡管を行った。金属管には、アメリカ石油協会グレードH40(以下、これを「API H40」と表記する)からなる外径7インチ(178mm)、肉厚0.231インチ(6mm)の炭素鋼管を用い、この鋼管の端部内径を、端部拡径率が5%となるように拡径した。

【0107】次に、拡径された金属管の端面を表面粗さRmaxが30μm以下となるように仕上げ、金属管の接合界面に、JIS BNi-3相当の組成を有する融点1050℃、厚さ50μmのNi系合金箔を介挿し、液相拡散接合を行った。さらに、得られた金属管接合体を、拡管率が25%となるようにマンドレルを用いて拡管した。

【0108】なお、接合部の加熱方法には、周波数3kHzの高周波電流を用いた高周波誘導加熱法を用いた。また、接合条件は、接合温度1300℃、保持時間180秒、加圧力4MPaとし、Ar雰囲気中で接合を行った。

【0109】(実施例2~3、比較例1、2)金属管30の端部拡径率を、それぞれ、0%(比較例1)、3%(比較例2)、20%(実施例2)、及び25%(実施例3)とした以外は、実施例1と同様の手順に従い、金属管接合体の製造及び拡管を行った。

【0110】実施例1~3、及び比較例1~2で得られた金属管接合体について、接合後に接合部の内周面側に発生した段差の最大値(以下、これを単に「最大段差」という)を測定した。また、拡管後の接合部表面について浸透探傷試験を行い、割れの有無を調べた。さらに、拡管された接合体の外周面に発生した段差のみをグラインダーにより研削して0.5mm以下とした後、この接合体から、API 1104号試験片を切り出し、引張試験を行った。結果を表1に示す。

【0111】

【表1】

実験 No		比較例 1	比較例 2	実施例 1	実施例 2	実施例 3
鋼管	材質	API H40	API H40	API H40	API H40	API H40
	寸 外径(インチ)	7.00	7.00	7.00	7.00	7.00
	法 肉厚(インチ)	0.231	0.231	0.231	0.231	0.231
端部拡張率 (%)		0	3	5	20	25
接合面表面粗さ (Rmax: μm)		30	30	30	30	30
インサート材	材質	BNi-3	BNi-3	BNi-3	BNi-3	BNi-3
	融点(°C)	1050	1050	1050	1050	1050
	厚さ(μm)	50	50	50	50	50
	形態	箔	箔	箔	箔	箔
接合温度(°C)		1300	1300	1300	1300	1300
保持時間(s)		180	180	180	180	180
加圧力(MPa)		4.0	4.0	4.0	4.0	4.0
接合雰囲気		Ar	Ar	Ar	Ar	Ar
接合部の加熱方法		高周波誘導加熱法 (3kHz)	高周波誘導加熱法 (3kHz)	高周波誘導加熱法 (3kHz)	高周波誘導加熱法 (3kHz)	高周波誘導加熱法 (3kHz)
接合部の最大段差 (mm)		4.0	1.0	0.5	0.5	0.5
拡張率 (%)		25	25	25	25	25
接合部表面の浸透探傷試験結果		割れ有り	割れ有り	割れ無し	割れ無し	割れ無し
引張試験結果	引張強さ(MPa)	283	467	716	718	717
	破断位置	接合界面	接合界面	母材	母材	母材
総合評価		×	△	○	○	○

【0112】端部拡張率を0%とした比較例1では、最大段差は、4mmに達した。また、拡張後の浸透探傷試験において、接合部に多数の亀裂が認められた。さらに、引張強度は283MPaの低強度を示し、試験片は40接合界面から破断した。

【0113】端部拡張率を3%とした比較例2では、最大段差は、1mmに減少した。また、拡張後の浸透探傷試験において、接合部にはかなりの亀裂が認められたが、亀裂の数は比較例1より少なかった。これに対応して、引張強度は、467MPaまで向上したが、試験片は、接合界面から破断した。

【0114】これに対し、端部拡張率をそれぞれ、5%、20%、及び25%とした実施例1、2及び3では、最大段差は、いずれも0.5mmに減少した。ま

た、拡張後の浸透探傷試験において、いずれも接合界面には亀裂は認められなかった。さらに、接合強度は、いずれも母材と同等である700MPa以上を示し、試験片は、母材側から破断した。

【0115】以上の結果から、金属管を接合する前に、金属管の端部内径を所定の端部拡張率以上の値となるように拡張すると、最大段差を小さくすることができることがわかった。また、端部拡張率を大きくするほど、拡張時に接合部に亀裂が発生しにくくなり、接合強度の高い金属管接合体が得られることがわかった。

【0116】(実施例4)方法Aを用いて、金属管接合体の拡張を行った。金属管には、API H40からなる外径7インチ(178mm)、肉厚0.231インチ(6mm)の炭素鋼管を用い、この鋼管の端部内径を、

端部拡張率が15%となるように拡張した。

【0117】次に、拡張された金属管の端面を表面粗さ R_{max} が $30\mu\text{m}$ 以下となるように仕上げ、金属管の接合界面に、融点 1200°C 、厚さ $40\mu\text{m}$ の $\text{Fe}-3\text{B}-3\text{Si}-1\text{C}$ 合金箔を介挿し、液相拡散接合を行った。さらに、得られた金属管接合体を、拡張率が25%となるようにマンドレルを用いて拡張した。

【0118】なお、接合部の加熱方法には、周波数 3kHz の高周波電流を用いた高周波誘導加熱法を用いた。また、接合条件は、接合温度 1250°C 、保持時間 60 秒、加圧力 4MPa とし、 Ar 雰囲気中で接合を行った。

【0119】(実施例5) インサート材として、 JIS BNi-5 相当の組成を有する融点 1140°C 、厚さ $40\mu\text{m}$ の Ni 系合金箔を用い、 1300°C に 120 秒保持した以外は、実施例4と同様の手順に従い、金属管接合体の製造及び拡張を行った。

【0120】(実施例6) インサート材として、 JIS BNi-5 相当の組成を有する融点 1140°C 、厚さ $40\mu\text{m}$ の Ni 系合金箔を用い、接合温度を 1400°C 、保持時間を 300 秒とした以外は、実施例4と同様の手順に従い、金属管接合体の製造及び拡張を行った。

【0121】(比較例3) インサート材として、融点 1290°C 、厚さ $40\mu\text{m}$ の $\text{Fe}-2\text{B}-1\text{Si}$ 合金箔を用い、接合温度を 1400°C 、保持時間を 300 秒、加圧力を 5MPa とした以外は、実施例4と同様の手順に従い、金属管接合体の製造及び拡張を行った。

【0122】実施例4~6、及び比較例3で得られた金属管接合体について、実施例1と同様の手順に従い、最大段差、浸透探傷試験、及び引張試験を行った。結果を表2に示す。

【0123】

【表2】

実験 N		比較例 3	実施例 4	実施例 5	実施例 6
鋼管	材質	API H40	API H40	API H40	API H40
	寸 外径(インチ)	7.00	7.30	7.00	7.00
	法 肉厚(インチ)	0.231	0.231	0.231	0.231
端部拡張率 (%)		15	15	15	15
接合面表面粗さ (Rmax: μm)		30	30	30	30
インサート材	材質	Fe-28-1Si	Fe-38-3Si-1C	BNi-5	BNi-5
	融点(°C)	1290	1200	1140	1140
	厚さ(μm)	40	40	40	40
	形態	箔	箔	箔	箔
接合温度(°C)		1400	1250	1300	1400
保持時間(s)		300	60	120	300
加圧力(MPa)		5.0	4.0	4.0	5.0
接合雰囲気		Ar	Ar	Ar	Ar
接合部の加熱方法		高周波誘導加熱法 (3kHz)	高周波誘導加熱法 (3kHz)	高周波誘導加熱法 (3kHz)	高周波誘導加熱法 (3kHz)
接合部の最大段差 (mm)		0.5	0.5	0.5	0.5
拡張率 (%)		25	25	25	25
接合部表面の浸透探傷試験結果		割れ有り	割れ無し	割れ無し	割れ無し
引張試験結果	引張強さ(MPa)	417	719	720	722
	破断位置	接合界面	母材	母材	母材
総合評価		△	○	○	○

【0124】融点が1290°Cであるインサート材を用いた比較例3では、保持時間を300秒としたにもかかわらず、拡張後の浸透探傷試験において、接合部に亀裂が認められた。また、引張強度は、417MPaであり、試験片は、接合界面から破断した。これは、インサート材の融点が高いために、接合界面において元素の拡散が十分に行われず、接合界面近傍の変形能が低下しているためと考えられる。

【0125】これに対し、融点が1200°Cであるインサート材を用いた実施例4、並びに融点が1140°Cであるインサート材を用いた実施例5及び6は、拡張後の浸透探傷試験において、いずれも接合界面には亀裂が認められなかった。また、接合強度は、いずれも母材と同

等である700MPa以上を示し、試験片は、母材側から破断した。

【0126】なお、実施例3～6及び比較例3においては、金属管の端部拡張率をいずれも15%としているので、最大段差は、いずれも0.5mmであった。

【0127】以上の結果から、金属管を液相拡散接合する場合において、融点が1200°C以下のインサート材を用いると、拡張後に、接合部に亀裂が発生することはなく、接合強度の高い金属管接合体が得られることがわかった。

【0128】(実施例7)方法Aを用いて、金属管接合体の拡張を行った。金属管には、API H40からなる外径7インチ(178mm)、肉厚0.231インチ

(6mm)の炭素鋼管を用い、この鋼管の端部内径を、端部拡張率が15%となるように拡張した。

【0129】次に、拡張された金属管の端面を表面粗さRmaxが30μm以下となるように仕上げ、金属管の接合界面に、JIS B Ni-5相当の組成を有する融点1140°Cの鱗片状Ni系合金を厚さ100μmとなるように介挿し、液相拡散接合を行った。さらに、得られた金属管接合体を、拡張率が25%となるようにマンドレルを用いて拡張した。

【0130】なお、接合部の加熱方法には、周波数3kHzの高周波電流を用いた高周波誘導加熱法を用いた。また、接合条件は、接合温度1300°C、保持時間180秒、加圧力4MPaとし、Ar雰囲気中で接合を行った。

【0131】(実施例8)インサート材として、JIS B Ni-5相当の組成を有するNi系合金粉末を用い、これを厚さ30μmとなるように金属管の接合界面に介挿し、接合温度に60秒間保持した以外は、実施例7と同様の手順に従い、金属管接合体の製造及び拡張を行った。

【0132】(実施例9)インサート材として、JIS

B Ni-5相当の組成を有する厚さ40μmのNi系合金箔を用い、接合温度を1250°C、保持時間を60秒とした以外は、実施例7と同様の手順に従い、金属管接合体の製造及び拡張を行った。

【0133】(比較例4)インサート材として、JIS B Ni-5相当の組成を有する厚さ200μmのNi系合金箔を用い、接合温度を1400°C、保持時間を300秒とした以外は、実施例7と同様の手順に従い、金属管接合体の製造及び拡張を行った。

【0134】(比較例5)インサート材として、JIS B Ni-5相当の組成を有する厚さ40μmのNi系合金箔を用い、接合温度を1450°C、保持時間を60秒とした以外は、実施例7と同様の手順に従い、金属管接合体の製造及び拡張を行った。

【0135】実施例7~9、及び比較例4~5で得られた金属管接合体について、実施例1と同様の手順に従い、最大段差、浸透探傷試験、及び引張試験を行った。結果を表3に示す。

【0136】

20 【表3】

実験 No		比較例4	実施例7	実施例8	実施例9	比較例5
鋼管	材質	API H40	API H40	API H40	API H40	API H40
	寸 外径(インチ)	7.00	7.00	7.00	7.00	7.00
	法 肉厚(インチ)	0.231	0.231	0.231	0.231	0.231
端部拡張率 (%)		15	15	15	15	15
接合面表面粗さ (Rmax: μm)		30	30	30	30	30
インサート材	材質	BNi-5	BNi-5	BNi-5	BNi-5	BNi-5
	融点 (°C)	1140	1140	1140	1140	1140
	厚さ (μm)	200	100	30	40	40
	形態	箔	銅片	粉末	箔	箔
接合温度 (°C)		1400	1300	1300	1250	1450
保持時間 (s)		300	180	60	60	60
加圧力 (MPa)		5.0	4.0	4.0	4.0	2.0
接合雰囲気		Ar	Ar	Ar	Ar	Ar
接合部の加熱方法		高周波誘導加熱法 (3kHz)	高周波誘導加熱法 (3kHz)	高周波誘導加熱法 (3kHz)	高周波誘導加熱法 (3kHz)	高周波誘導加熱法 (3kHz)
接合部の最大段差 (mm)		0.5	0.5	0.5	0.5	0.5
拡張率 (%)		25	25	25	25	25
接合部表面の 浸透探傷試験結果		割れ有り	割れ無し	割れ無し	割れ無し	割れ有り
引張 試験 結果	引張強さ (MPa)	588	718	721	718	657
	破断位置	接合界面	母材	母材	母材	接合界面
総合評価		△	○	○	○	△

【0137】インサート材の厚さを200 μmとした比較例4では、保持時間を300秒としたにもかかわらず、拡張後の浸透探傷試験において、接合部に亀裂が認められた。また、引張強度は、588 MPaであり、試験片は、接合界面から破断した。これは、インサート材が厚いために、インサート材に含まれる元素の拡散が十分に行われず、接合界面近傍の変形能が低下したためと考えられる。

【0138】また、接合温度を1450°Cとした比較例5では、接合部近傍に溶損が発生していた。また、拡張後の浸透探傷試験において、接合部に亀裂が認められた。さらに、引張強度は、657 MPaであり、試験片は、接合界面から破断した。

【0139】これに対し、インサート材の厚さを100

μm以下とし、かつ接合温度を1400°C以下とした実施例7、8及び9では、いずれも接合部に溶損は認められず、拡張後の浸透探傷試験においても、接合界面には亀裂が認められなかった。また、接合強度は、いずれも母材と同等である700 MPa以上を示し、試験片は、母材側から破断した。

【0140】なお、実施例7～9及び比較例4～5においては、金属管の端部拡張率をいずれも15%としているので、最大段差は、いずれも0.5 mmであった。

【0141】以上の結果から、金属管を液相拡散接合する場合において、インサート材の厚さを100 μm以下とすると、拡張後に接合部に亀裂が発生することなく、接合強度の高い金属管接合体が得られることがわかった。また、接合部の溶損を抑制するには、接合温度を

1400℃以下とする必要があることがわかった。

【0142】(実施例10)方法Aを用いて、金属管接合体の拡管を行った。金属管には、API H40からなる外径7インチ(178mm)、肉厚0.231インチ(6mm)の炭素鋼管を用い、この鋼管の端部内径を、端部拡径率が15%となるように拡径した。

【0143】次に、拡径された金属管の端面を表面粗さRmaxが30μm以下となるように仕上げ、金属管の接合界面に、JIS B Ni-5相当の組成を有する融点1140℃、厚さ40μmのNi系合金箔を介挿し、液相拡散接合を行った。さらに、得られた金属管接合体を、拡管率が25%となるようにマンドレルを用いて拡管した。

【0144】なお、接合部の加熱方法には、周波数3kHzの高周波電流を用いた高周波誘導加熱法を用いた。また、接合条件は、接合温度1400℃、保持時間30秒、加圧力5MPaとし、Ar雰囲気中で接合を行った。

【0145】(実施例11)接合温度における保持時間を300秒、加圧力を1.5MPaとした以外は、実施

例10と同様の手順に従い、金属管接合体の製造及び拡管を行った。

【0146】(比較例6)接合温度における保持時間を15秒とした以外は、実施例10と同様の手順に従い、金属管接合体の製造及び拡管を行った。

【0147】(比較例7)インサート材として、JIS B Ni-5相当の組成を有する厚さ30μmのNi系合金箔を用い、接合温度における保持時間を300秒、加圧力を1MPaとした以外は、実施例10と同様の手順に従い、金属管接合体の製造及び拡管を行った。

【0148】(比較例8)接合温度を1250℃、保持時間を300秒、加圧力を7MPaとした以外は、実施例10と同様の手順に従い、金属管接合体の製造及び拡管を行った。

【0149】実施例10~11、及び比較例6~8で得られた金属管接合体について、実施例1と同様の手順に従い、最大段差、浸透探傷試験、及び引張試験を行った。結果を表4に示す。

【0150】

【表4】

実験 No		比較例 6	実施例 10	比較例 7	実施例 11	比較例 8
鋼管	材質	API H40	API H40	API H40	API H40	API H40
	寸 外径(インチ)	7.00	7.00	7.00	7.00	7.00
	法 肉厚(インチ)	0.231	0.231	0.231	0.231	0.231
端部拡張率 (%)		15	15	15	15	15
接合面表面粗さ (Rmax : μm)		30	30	30	30	30
インサート材	材質	BNi-5	BNi-5	BNi-5	BNi-5	BNi-5
	融点(°C)	1140	1140	1140	1140	1140
	厚さ(μm)	40	40	30	40	40
	形態	箔	箔	箔	箔	箔
接合温度(°C)		1400	1400	1400	1400	1250
保持時間(s)		15	30	300	300	300
加圧力(MPa)		5.0	5.0	1.0	1.5	7.0
接合雰囲気		Ar	Ar	Ar	Ar	Ar
接合部の加熱方法		高周波誘導加熱法 (3kHz)	高周波誘導加熱法 (3kHz)	高周波誘導加熱法 (3kHz)	高周波誘導加熱法 (3kHz)	高周波誘導加熱法 (3kHz)
接合部の最大段差 (mm)		0.5	0.5	0.5	0.5	0.5
拡張率 (%)		25	25	25	25	25
接合部表面の浸透探傷試験結果		割れ有り	割れ無し	割れ有り	割れ無し	割れ有り
引張試験結果	引張強度 (MPa)	563	709	628	714	687
	破断位置	接合界面	母材	接合界面	母材	接合界面
総合評価		△	○	△	○	△

【0151】接合温度における保持時間を15秒とした比較例6では、拡張後の浸透探傷試験において、接合部に亀裂が認められた。また、引張強度は、563MPaであり、試験片は、接合界面から破断した。これは、保持時間が短いために、接合界面における元素の拡散が十分に行われず、接合界面近傍の変形能が低下したためと考えられる。

【0152】また、加圧力を1MPaとした比較例7では、接合温度における保持時間を300秒としたにもかかわらず、拡張後の浸透探傷試験において、接合部に亀裂が認められた。また、引張強度は、628MPaであり、試験片は、接合界面から破断した。これは、加圧力が低いために、接合界面が十分に密着せず、部分的に未接合部が発生し、これにより接合界面全体の変形能が低

下したためと考えられる。

【0153】さらに、加圧力を7MPaとした比較例8では、接合温度を1250°Cまで下げたにもかかわらず、接合部近傍に過大な変形が生じた。また、拡張後の浸透探傷試験において、接合部に亀裂が認められた。さらに、引張強度は、687MPaであり、試験片は、接合界面から破断した。

【0154】これに対し、加圧力を5MPa、保持時間を30秒とした実施例10、及び加圧力を1.5MPa、保持時間を300秒とした実施例11では、いずれも拡張後の浸透探傷試験においても、接合界面には亀裂が認められなかった。また、接合強度は、いずれも母材と同等である700MPa以上を示し、試験片は、母材側から破断した。

【0155】なお、実施例10～11及び比較例6～8においては、金属管の端部拡張率をいずれも15%としているので、最大段差は、いずれも0.5mmであった。

【0156】以上の結果から、金属管を液相拡散接合する場合において、加圧力を1.5MPa以上5MPa以下とすると、拡張後に接合部に亀裂が発生することはなく、接合強度の高い金属管接合体が得られることがわかった。

【0157】(実施例12)方法Aを用いて、金属管接合体の拡張を行った。金属管には、マルテンサイト系ステンレス鋼の一種である、アメリカ石油協会グレードLC52-1200(以下、これを「LC52-1200」という)からなる外径10.75インチ(269mm)、肉厚0.5インチ(13mm)の鋼管を用い、この鋼管の端部内径を、端部拡張率が15%となるように拡張した。

【0158】次に、拡張された金属管の端面を表面粗さ R_{max} が50 μ m以下となるように仕上げ、金属管の接合界面に、JIS BNi-5相当の組成を有する融点1140 $^{\circ}$ C、厚さ40 μ mのNi系合金箔を介挿し、液相拡散接合を行った。さらに、得られた金属管接合体を、拡張率が25%となるようにマンドレルを用いて拡張した。

【0159】なお、接合部の加熱方法には、周波数3kHzの高周波電流を用いた高周波誘導加熱法を用いた。また、接合条件は、接合温度1300 $^{\circ}$ C、保持時間12

0秒、加圧力4MPaとし、Ar雰囲気中で接合を行った。

【0160】(実施例13)接合温度を1350 $^{\circ}$ C、保持時間を210秒、加圧力を3.5MPaとし、誘導コイルに流す高周波電流の周波数を100kHzとした以外は、実施例12と同様の手順に従い、金属管接合体の製造及び拡張を行った。

【0161】(実施例14)接合温度を1350 $^{\circ}$ C、保持時間を210秒、加圧力を3.5MPaとし、周波数25kHzの高周波電流を用いた高周波直接通電加熱法により接合を行った以外は、実施例12と同様の手順に従い、金属管接合体の製造及び拡張を行った。

【0162】(比較例9)接合面の表面粗さ R_{max} を100 μ mとし、接合温度を1400 $^{\circ}$ C、保持時間を300秒とした以外は、実施例12と同様の手順に従い、金属管接合体の製造及び拡張を行った。

【0163】(比較例10)接合温度における保持時間を300秒、加圧力を5MPaとし、誘導コイルに流す高周波電流の周波数を400kHzとした以外は、実施例12と同様の手順に従い、金属管接合体の製造及び拡張を行った。

【0164】実施例12～14、及び比較例9～10で得られた金属管接合体について、実施例1と同様の手順に従い、最大段差、浸透探傷試験、及び引張試験を行った。結果を表5に示す。

【0165】

【表5】

実験 No		比較例 9	実施例 1 2	比較例 1 0	実施例 1 3	実施例 1 4
銅管	材質	LC52-1200	LC52-1200	LC52-1200	LC52-1200	LC52-1200
	寸 外径(φ)	10.75	10.75	10.75	10.75	10.75
	法 肉厚(φ)	0.500	0.500	0.500	0.500	0.500
端部拡張率 (%)		15	15	15	15	15
接合面表面粗さ (Rmax: μm)		100	50	30	30	30
インサート材	材質	8Ni-5	8Ni-5	8Ni-5	8Ni-5	8Ni-5
	融点 (°C)	1140	1140	1140	1140	1140
	厚さ (μm)	40	40	40	40	40
	形態	箔	箔	箔	箔	箔
接合温度 (°C)		1400	1300	1400	1350	1350
保持時間 (s)		300	120	300	210	210
加圧力 (MPa)		5.0	4.0	5.0	3.5	3.5
接合雰囲気		Ar	Ar	Ar	Ar	Ar
接合部の加熱方法		高周波誘導加熱法 (3kHz)	高周波誘導加熱法 (3kHz)	高周波誘導加熱法 (430kHz)	高周波誘導加熱法 (100kHz)	高周波誘導加熱法 (25kHz)
接合部の最大段差 (mm)		0.5	0.5	0.5	0.5	0.5
拡張率 (%)		25	25	25	25	25
接合部表面の浸透探傷試験結果		割れ有り	割れ無し	割れ有り	割れ無し	割れ無し
引張試験結果	引張強度 (MPa)	477	655	431	658	653
	破断位置	接合界面	母材	接合界面	母材	母材
総合評価		×	○	×	○	○

【0166】接合界面の表面粗さRmaxを100μmとした比較例9では、相対的に高温、高圧、長時間の条件下で拡散接合を行ったにもかかわらず、拡張後の浸透探傷試験において、接合部に亀裂が認められた。また、引張強度は、477MPaであり、試験片は、接合界面から破断した。これは、表面粗さが粗いために、接合界面に存在する凹凸を溶融したNi合金で充填することができず、これにより接合界面全体の変形能が低下したためと考えられる。

【0167】また、周波数が400MPaである高周波電流を用いて誘導加熱した比較例10も同様に、相対的に高温、高圧、長時間の条件下で拡散接合を行ったにもかかわらず、拡張後の浸透探傷試験において、接合部に亀裂が認められた。また、引張強度は、431MPaで

あり、試験片は、接合界面から破断した。これは、周波数が高いために、接合界面全体が均一に加熱されず、金属管の内周面側に未接合部が発生し、これにより接合界面全体の変形能が低下したためと考えられる。

【0168】これに対し、接合界面の表面粗さRmaxを50μm以下とし、周波数が100kHz以下の高周波電流を用いた実施例12~14では、いずれも拡張後の浸透探傷試験において、接合部に亀裂は認められなかった。また、接合強度は、いずれも母材と同等である700MPa以上を示し、試験片は、母材側から破断した。

【0169】なお、実施例12~14及び比較例9~10においては、金属管の端部拡張率をいずれも15%としているので、最大段差は、いずれも0.5mmであっ

た。

【0170】以上の結果から、金属管を液相拡散接合する場合において、接合界面の表面粗さRmaxを50μm以下とすると、拡管後に接合部に亀裂が発生することではなく、接合強度の高い金属管接合体が得られることがわかった。また、接合界面を高周波誘導加熱又は高周波直接通電加熱する場合において、高周波電流の周波数を100kHz以下とすると、未接合部の発生に起因する変形能の低下を抑制できることがわかった。

【0171】(実施例15)方法Bを用いて、金属管接合体の拡管を行った。金属管には、API 40Hからなる外径7インチ(178mm)、肉厚0.231インチ(6mm)の炭素鋼管を用い、この鋼管の端部内径を、端部拡径率が10%となるように拡径した。

【0172】次に、拡径された金属管の端面に外ねじを形成し、この外ねじと螺合可能な内ねじを有する継手を介して、金属管同士を締結した。さらに、得られた金属管接合体を、拡管率が10%となるようにマンドレルを用いて拡管した。

【0173】(実施例16)金属管の端部拡径率を25%とし、拡管率25%で金属管接合体を拡管した以外は、実施例15と同様の手順に従い、金属管接合体の製*

*造及び拡管を行った。

【0174】(実施例16)金属管として、LC52-1200からなる外径10.75インチ(273mm)、肉厚0.5インチ(12.7mm)の鋼管を用い、金属管の端部拡径率を25%とし、拡管率25%で金属管接合体を拡管した以外は、実施例15と同様の手順に従い、金属管接合体の製造及び拡管を行った。

【0175】(比較例11)金属管の端部拡径率を0%とした以外は、実施例15と同様の手順に従い、金属管接合体の製造及び拡管を行った。

【0176】(比較例12)金属管として、LC52-1200からなる外径10.75インチ(273mm)、肉厚0.5インチ(12.7mm)の鋼管を用い、金属管の端部拡径率を15%とし、拡管率25%で金属管接合体を拡管した以外は、実施例15と同様の手順に従い、金属管接合体の製造及び拡管を行った。

【0177】実施例15~17、及び比較例11~12で得られた各金属管接合体について、水圧試験を行った。結果を表6に示す。

【0178】

【表6】

実験No		比較例11	実施例15	実施例16	実施例17	比較例12
鋼管	材質	API H10	API H40	API H40	LC52-1200	LC52-1200
	寸法 外径(インチ)	7.00	7.00	7.00	10.75	10.75
	寸法 肉厚(インチ)	0.231	0.231	0.231	0.500	0.500
端部拡径率(%)		0	0	25	25	15
拡管率(%)		10	10	25	25	25
水圧試験圧力 (psf)		2100	2100	2100	3000	3000
水圧試験結果		漏れ発生	良好	良好	良好	漏れ発生
締合評価		x	C	O	O	x

【0179】端部拡径率を0%とし、金属管接合体を拡管率10%で拡管した比較例11について、圧力2100psiで水圧試験を行ったところ、接合部から水漏れが発生した。

【0180】これに対し、端部拡径率及び拡管率を共に10%とした実施例15、並びに端部拡径率及び拡管率を共に25%とした実施例16は、いずれも圧力2100psiで水圧試験を行っても、接合部から水漏れが発生することはなかった。

【0181】また、端部拡径率を15%とし、金属管接合体を拡管率20%で拡管した比較例12について、圧力3000psiで水圧試験を行ったところ、接合部から水漏れが発生した。

【0182】これに対し、端部拡径率及び拡管率を共に25%とした実施例17では、圧力3000psiで水圧試験を行っても、接合部から水漏れが発生せず、良好な金属管接合体が得られた。

【0183】以上の結果から、ねじ接続法で接合された金属管接合体を拡管する場合において、端部拡径率以下の拡管率で拡管を行うと、気密性に優れた金属管接合体が得られることがわかった。

【0184】(実施例18)方法Cを用いて、金属管接合体の拡管を行った。金属管には、STKM12B(JIS G3445)からなる外径140mm、肉厚7mmの鋼管を用いた。この鋼管の端面を表面粗さRmaxが30μm以下となるように仕上げ、接合界面に、JIS B Ni-3相当の組成を有する融点1050℃、厚さ50μmのNi系合金箔を介挿し、拡散接合を行った。さらに、得られた金属管接合体を、拡管率が5~25%となるようにマンドレルを用いて拡管した。

【0185】なお、接合部の加熱方法には、周波数3kHzの高周波電流を用いた高周波誘導加熱法を用い、加熱コイルには、加熱幅が20mmとなるコイルと、40mmとなるコイルの2種類を用いた。また、接合条件

は、接合温度を1250~1350℃、保持時間を60~300秒、加圧力1~4MPaとし、Ar雰囲気中で接合を行った。さらに、横膨出率は、接合条件を変えることにより調整した。

【0186】得られた金属管接合体の横膨出率、膨出長さ、並びに拡管後の割れの有無及び引張強度を表7に示*

*す。なお、表7には、所定の拡管率で拡管された金属管の非接合部の引張強度(表7中、「母材」と表記)も併せて示した。

【0187】

【表7】

実験 番号	接合条件			横膨 出率 (%)	加熱 幅 (mm)	膨出 長さ (mm)	拡管前 の引張 強度 (MPa)	接合部拡管試験結果									
	接合 温度 (℃)	保持 時間 (s)	加圧力 (MPa)					拡管率5%		拡管率10%		拡管率15%		拡管率20%		拡管率25%	
								割れ 有無	引張 強度 (MPa)	割れ 有無	引張 強度 (MPa)	割れ 有無	引張 強度 (MPa)	割れ 有無	引張 強度 (MPa)	割れ 有無	引張 強度 (MPa)
1	1250	60	1.0	1.00	20	0	484	無	515	有	-	有	-	有	-	有	-
2	1250	60	1.0	1.00	40	0	483	無	517	有	-	有	-	有	-	有	-
3	1250	60	4.0	1.02	20	46	480	無	511	無	550	無	537	有	-	有	-
4	1250	60	4.0	1.02	40	69	466	無	501	無	543	無	558	無	564	有	-
5	1350	60	2.0	1.04	20	45	485	無	502	無	544	無	531	無	559	有	-
6	1350	60	2.0	1.04	40	60	476	無	482	無	532	無	540	無	549	無	554
7	1300	60	4.0	1.04	20	43	483	無	480	無	541	無	519	無	555	無	562
8	1300	60	4.0	1.04	40	85	488	無	471	無	533	無	540	無	547	無	551
9	1350	60	4.0	1.08	20	47	486	無	488	無	525	無	541	無	547	無	557
10	1350	60	4.0	1.04	40	90	460	無	458	無	478	無	526	無	539	無	551
11	1350	300	4.0	1.14	20	30	482	無	480	無	488	無	509	無	538	無	543
母材	-	-	-	-	-	-	490	無	515	無	503	無	575	無	504	無	591

【0188】表7より、加熱幅の長い加熱コイルを用いるほど、膨出長さが長くなることわかる。すなわち、加熱幅を20mmとすると、膨出長さは、40~50mm

となり、加熱幅を40mmとすると、膨出長さは、80~90mmとなることわかる。

【0189】また、表7より、膨出長さを40~50mmとした場合、横膨出率が大きくなるほど、より大きな拡管率で拡管を行うことが可能な金属管接合体が得られることわかる。

【0190】すなわち、横膨出率が1.00の場合、拡管率が10%の時に既に接合界面に割れが発生し、健全な金属管接合体が得られなかった(実験番号1)。横膨出率を1.02とすると、拡管率が15%以下の場合には、健全な金属管接合体が得られたが、拡管率が20%以上になると、接合部に亀裂が発生した(実験番号3)。

【0191】これに対し、横膨出率を1.04以上(実験番号5、7、9、11)とすると、拡管率を20%としても接合部に亀裂が発生することなく、母材と同等の強度を有する健全な金属管接合体が得られた。

【0192】膨出長さを80~90mmとした場合も同様であり、横膨出率が大きくなるほど、より大きな拡管率で拡管を行うことが可能な金属管接合体が得られてい

ることがわかる(実験番号2、4、6、8、10)。

【0193】さらに、表7より、横膨出率を同一とした場合、膨出長さが長くなるほど、拡管率の大きな拡管に耐えうる金属管接合体が得られる傾向があることわかる。すなわち、横膨出率が1.02、膨出長さが40mmである場合には、拡管率20%で拡管とすると、接合部に亀裂が発生した(実験番号3)。一方、膨出長さを80mmとした場合には、拡管率20%で拡管しても、接合部に亀裂が発生することなく、母材と同等の強度を有する健全な接合体が得られている(実験番号4)。

【0194】同様に、横膨出率が1.04、膨出長さが45mmである場合には、拡管率25%で拡管すると、接合部に亀裂が発生した(実験番号5)。一方、膨出長さを90mmとした場合には、拡管率25%で拡管しても、接合部に亀裂が発生することなく、母材と同等の強度を有する健全な接合体が得られている(実験番号6)。

【0195】以上の結果から、端部が拡径されていない金属管を突き合わせ、拡散接合の際に接合界面近傍を所定の横膨出率で樽型に変形させると、高い拡管率で拡管を行った場合であっても、接合部に亀裂が発生することなく、接合強度の高い健全な金属管接合体が得られることがわかった。

30

40

50

【0196】(実施例19)方法A'を用いて、金属管接合体の拡管を行った。金属管には、API H40からなる外径7インチ(178mm)、肉厚0.231インチ(6mm)の炭素鋼管を用い、この鋼管の端部内径を、端部拡径率が5%となるように拡径した。

【0197】次に、拡径された金属管の端面に開先を形成し、ガスシールドアーク溶接法により金属管の溶接を行った。さらに、得られた金属管接合体を、拡管率が25%となるようにマンドレルを用いて拡管した。

【0198】なお、溶接は、溶接ワイヤとしてJIS YGW21(φ1.2mm)を用い、シールドガスには、Ar+20%CO₂の混合ガスを用い、溶接電流280Aの条件下で行った。

*【0199】(実施例20~21、比較例13~14)金属管30の端部拡径率を、それぞれ、0% (比較例13)、3% (比較例14)、10% (実施例20)、及び15% (実施例21)とした以外は、実施例19と同様の手順に従い、金属管接合体の製造及び拡管を行った。

【0200】実施例19~21、及び比較例13~14で得られた金属管接合体について、実施例1と同様の手順に従い、浸透探傷試験、及び引張試験を行った。結果を表8に示す。

【0201】
【表8】

実験 No		比較例13	比較例14	実施例19	実施例20	実施例21
鋼管	材質	API H40	API H40	API H40	API H40	API H40
	寸 外径(インチ)	7.00	7.00	7.00	7.00	7.00
	法 肉厚(インチ)	0.231	0.231	0.231	0.231	0.231
端部拡径率 (%)		0	3	5	10	15
溶接方法		ガスシールドアーク溶接法 溶接ワイヤ: JIS YGW21 (φ1.2mm) シールドガス: Ar+20%CO ₂ 溶接電流: 280A				
拡管率 (%)		25	25	25	25	25
接合部表面の浸透探傷試験結果		割れ有り	割れ有り	割れ無し	割れ無し	割れ無し
引張試験結果	引張強さ (MPa)	317	495	721	719	720
	破断位置	溶接部	溶接部	母材	母材	母材
総合評価		×	△	○	○	○

【0202】端部拡径率を0%とした比較例13では、拡管後の浸透探傷試験において、接合部に多数の亀裂が認められた。さらに、引張強度は317MPaの低強度を示し、試験片は溶接部から破断した。

【0203】端部拡径率を3%とした比較例14でも同様に、拡管後の浸透探傷試験において、接合部にはかなりの亀裂が認められたが、亀裂の数は比較例13より少なかった。これに対応して、引張強度は、495MPaまで向上したが、試験片は、溶接部から破断した。

【0204】これに対し、端部拡径率をそれぞれ、5%、10%、及び15%とした実施例19、20及び21では、拡管後の浸透探傷試験において、いずれも接合界面には亀裂は認められなかった。さらに、接合強度は、いずれも母材と同等である700MPa以上を示し、試験片は、母材側から破断した。

【0205】以上の結果から、金属管を溶接する前に、

金属管の端部内径を所定の端部拡径率以上の値となるように拡径すると、端部拡径率を大きくするほど、拡管時に接合部に亀裂が発生しにくくなり、接合強度の高い金属管接合体が得られることがわかった。

【0206】以上、本発明の実施の形態について詳細に説明したが、本発明は、上記実施の形態に何ら限定されるものではなく、本発明の要旨を逸脱しない範囲で種々の変更が可能である。

【0207】例えば、拡管に用いるマンドレルの形状は、特に限定されるものではなく、テーパ付のマンドレルを用いてもよく、あるいは、テーパ面にローラを有するマンドレルを用いてもよい。

【0208】また、マンドレルの駆動手段も特に限定されるものではない。例えば、マンドレルの底面に軸を固定し、その軸を用いて、マンドレルを金属管接合体の中に押し込んでよく、あるいは、マンドレルの底面に液

*

40

50

圧を付与し、液圧により金属管接合体の中を一端から他端に向かって移動させるようにしてもよい。

【0209】また、上記実施の形態では、拡散接合法、ねじ接続法又は溶接法を用いて、接合部の内径が非接合部の内径より大きくなっている金属管接合体を接合しているが、金属管接合体の接合方法は、これらに限定されるものではない。例えば、予め端部近傍の内径が拡張された金属管を、摩擦圧接法により接合して金属管接合体としても良い。

【0210】さらに、本発明に係る拡張用金属管接合体及びその製造方法は、地中に埋設されるケーシング等の油井管及びその製造方法として特に好適であるが、本発明の用途は、油井管に限定されるものではなく、ガス坑井、地熱坑井、温泉井戸、水井戸等に用いられるケーシング、あるいは、地表に敷設されるラインパイプや、プラント用配管及びその製造方法としても用いることができ、これにより上記実施の形態と同様の効果を得ることができる。

【0211】

【発明の効果】本発明に係る拡張用金属管接合体及びその製造方法は、接合部の内径が非接合部の内径より大きくなっている金属管接合体を、マンドレル等の工具を用いて拡張するので、金属管接合体を拡張する際の変形抵抗が小さくなる。そのため、拡張作業を円滑に行うことができ、拡張作業の省動力化も図られるという効果がある。

【0212】また、予め金属管の端部を所定の端部拡張率で拡張し、このような金属管を突き合わせて拡散接合又は溶接すれば、接合部の内径が非接合部の内径より大きくなっている金属管接合体を容易に得ることができる。

【0213】また、このような金属管接合体を拡張した場合には、非接合部の塑性歪に比して、接合部の塑性歪を小さくすることができる。そのため、拡散接合又は溶接した時に熱影響部が発生し、接合部近傍の変形能が低下している場合であっても、接合部に亀裂が発生しにくくなり、強度及び気密性に優れた金属管接合体が得られるという効果がある。

【0214】また、端部内径が所定の端部拡張率で拡張された金属管をねじ接続法により接合して金属管接合体とし、端部拡張率以下の拡張率で金属管接合体を拡張すれば、ねじ部が塑性変形することがないので、ねじの緩みに起因する気密性の低下が生じないという効果がある。

10

20

30

40

【0215】また、端部が拡張されていない金属管同士を突き合わせ、拡散接合すると同時に接合部を所定の横断面率で樽型に変形させた場合であっても、接合部の内径が非接合部の内径より大きくなっている金属管接合体を容易に得ることができる。そのため、このような金属管接合体を所定の拡張率で拡張すれば、強度及び気密性に優れた金属管接合体が得られるという効果がある。

【0218】さらに、予め金属管の端部を所定の端部拡張率で拡張し、このような金属管を突き合わせて拡散接合した場合には、各金属管の寸法にばらつきがあっても、接合部の内周面側に発生する段差を小さくすることができる。そのため、拡張を行っても、応力集中に起因する亀裂の発生のおそれがなく、また接合部に腐食性物質が滞留することもないので、強度、疲労特性及び耐食性に優れた金属管接合体が得られるという効果がある。

【0217】以上のように、本発明に係る拡張用金属管接合体及びその製造方法によれば、拡張に要する消費エネルギーが少なく、気密性及び強度に優れ、しかも接合部に発生する段差の小さい金属管接合体が容易に得られるので、これを例えば、油井管や、ラインパイプ等に適用すれば、石油掘削作業やパイプ敷設作業の大幅なコストダウンと、信頼性の向上に寄与するものであり、産業上その効果の極めて大きい発明である。

【図面の簡単な説明】

【図1】本発明の第1の実施の形態に係る拡張用金属管接合体の製造方法を示す工程図である。

【図2】図1(d)に示す拡張用金属管接合体の拡張方法を示す工程図である。

【図3】本発明の第2の実施の形態に係る拡張用金属管接合体の製造方法を示す工程図である。

【図4】図2(d)に示す拡張用金属管接合体の拡張方法を示す工程図である。

【図5】図5(a)~(c)は、本発明の第3の実施の形態に係る拡張用金属管接合体の製造方法を示す工程図であり、図5(d)は、図5(c)に示す拡張用金属管接合体の拡張方法を示す図である。

【図6】油井の一般的な構造を示す断面図である。

【図7】ねじ接続法(メカニカルカップリング法)を示す断面図である。

【符号の説明】

- 30、40、50 金属管
- 32、42、52 金属管接合体
- 34 マンドレル

【図1】

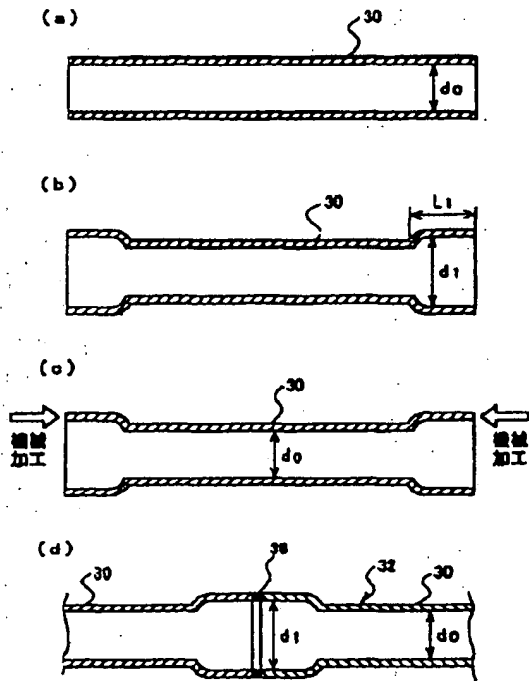

【図3】

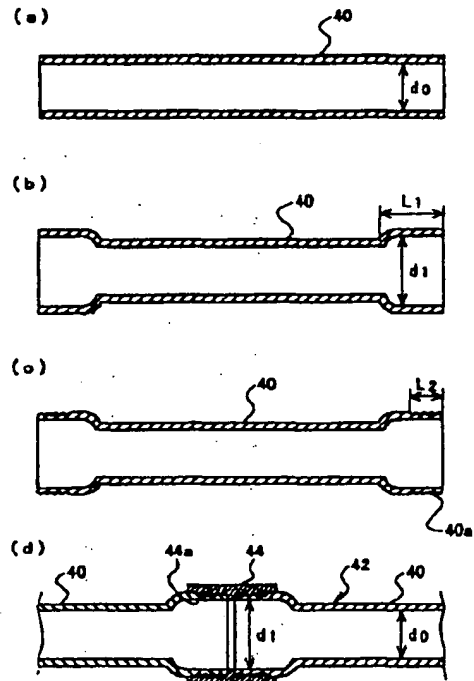

【図2】

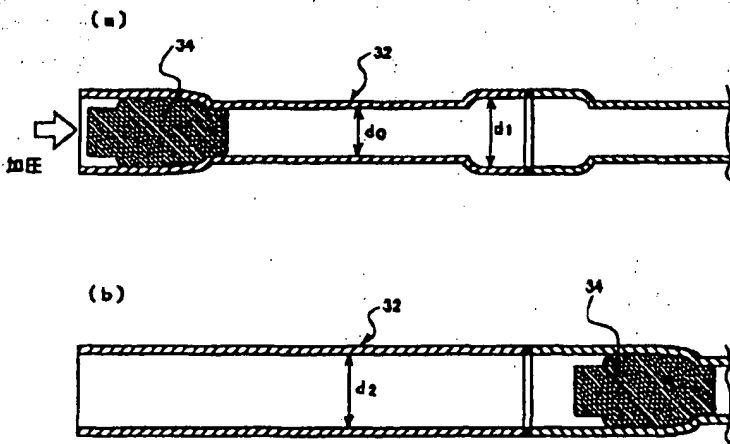

【図6】

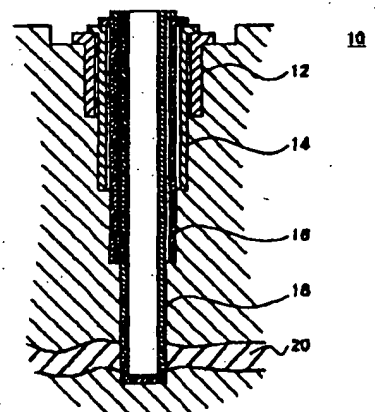

【図4】

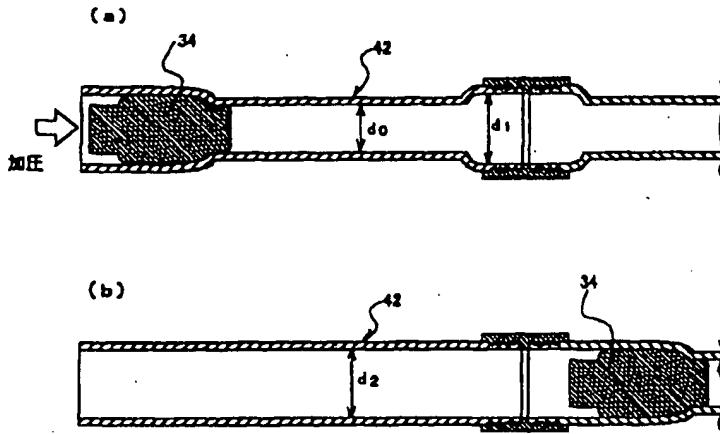

【図7】

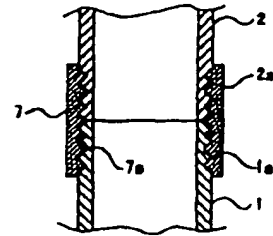

【図5】

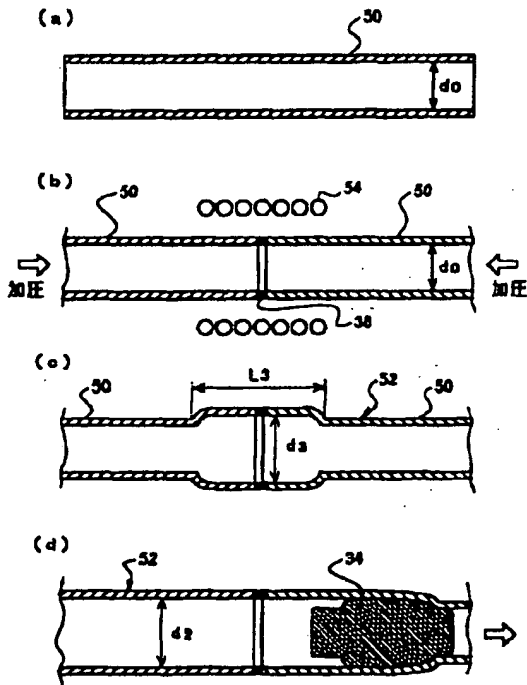

フロントページの続き

(51)Int.Cl.
// E 2 1 B 17/08

識別記号

F I
E 2 1 B 17/08

テラード (参考)

(72)発明者 稲垣 繁幸
愛知県名古屋市南区天白町3-9-111
大同特殊鋼天白荘205

Fターム(参考) 3H013 BA02 GA01
4E067 AA01 AB02 AB05 AD03 AD04
AD07 BA03 BA05 BH01 BH03
DA00 DA09 DA13 DB02 DC03
DC06 DC07 EA03 EC06
4E081 AA08 BA03 BA04 BA05 BA27
CA07 DA11 DA23 DA35

(19) Japan Patent Office (JP)
(12) Japanese Unexamined Patent Application Publication (A)
(11) Japanese Unexamined Patent Application Publication Number 2000-107870
(P2000-107870A)
(43) Publication Date: April 18, 2000

(51) Int. Cl. ⁷	Identification No.	FI	Theme Code (Reference)
B 23 K 20/00	310	B 23 K 20/00	310 L 3H013
B 21 D 41/02		B 21 D 41/02	D 4E067
B 23 K 9/028		B 23 K 9/028	B 4E081
F 16 L 13/02		F 16 L 13/02	
15/00		15/00	

Application for Inspection: Not yet filed
No. of Claims: 9 OL (Total pages 25)
Continued on the last page

(21) Application No.: Patent Application H10-286403
(22) Application Filed: October 8, 1998

(71) Applicant: 000003713
Daido Steel Company, Incorporated
1-11-18 Nishiki, Naka-ku, Nagoya-shi, Aichi-ken

(72) Inventor: Sueo Hiyamizu
501 Yagoto Sun Heights, 2-311 Omoteyama, Tenpaku-ku, Nagoya-shi,
Aichi-ken

(72) Inventor: [Hakuji] Horio
18 Minami-Shikamochi, Kagiya-cho, Toukai-shi, Aichi-ken
Daido Steel, Chita Dormitory C-317

(72) Inventor: Kazushige [Kiaki]
2-38 [illegible], Midori-ku, Nagoya-shi, Aichi-ken

(74) Agent: 100095669
Patent Attorney Noboru Ueno (1 Outside Individual)

Continued on the last page

(54) Title of the Invention: Metal Pipe Joint for Pipe Expansion and the Manufacturing Method Thereof

(57) Summary
(Problem)

Provide a metal pipe joint for pipe expansion and its manufacturing method, wherein even in the case of pipe expansion, (a) there is no decrease in the strength or the airtightness of the junction, (b) there is little deformation resistance at the time of pipe expansion, and (c) it is possible to reduce the level differences that occur in the junction.

(Means for Solving the Problem)

Obtain metal pipe joints 32 and 52 in which the internal diameters of the junctions are greater than the internal diameters of the non-conjugative regions, by either (a) diffusion bonding or welding to one another metal pipes 30 whose internal diameters in the vicinity of the ends have been expanded such that the end diameter expansion rate is greater than 5%, or (b) diffusing bonding metal pipe 50, whose internal diameter in the vicinity of the end has not been expanded, such that it reaches a prescribed lateral expansion rate.

Furthermore, obtain metal pipe joint 42 in which the internal diameter of the junction is greater than the internal diameter of the non-conjugative regions by mechanically fastening to one another metal pipes 40 whose internal diameters toward the ends have been expanded such that the end diameter expansion rate is greater than 10%.

[see source for drawings]

(c)

Machine work

Machine work

(Scope of Patent Claims)

(Claim 1)

A metal pipe joint for pipe expansion comprised of a plurality of bonded metal pipes, wherein the internal diameter of the junction is greater than the internal diameter of the non-conjugative regions.

(Claim 2)

A manufacturing method for a metal pipe joint for pipe expansion in which the internal diameter in the vicinity of the end of the metal pipe is expanded and said metal pipes are bonded to one another.

(Claim 3)

The manufacturing method for a metal pipe joint for pipe expansion according to Claim 2 in which the internal diameter in the vicinity of the end of said metal pipe is expanded such that the end diameter expansion rate is greater than 5%.

(Claim 4)

The manufacturing method for a metal pipe joint for pipe expansion according to either Claim 2 or Claim 3 in which the bonding method is a diffusion bonding method.

(Claim 5)

The manufacturing method for a metal pipe joint for pipe expansion according to either Claim 2 or Claim 3 in which the bonding method is an arc welding method.

(Claim 6)

A manufacturing method for a metal pipe joint for pipe expansion in which the internal diameter in the vicinity of the end of the metal pipe is expanded, thread is formed on the end of said metal pipe, and said metal pipes are mechanically fastened to one another with said thread.

(Claim 7)

The manufacturing method for a metal pipe joint for pipe expansion according to Claim 6 in which the internal diameter in the vicinity of the end of said metal pipe is expanded such that the end diameter expansion rate is greater than 10%.

(Claim 8)

A manufacturing method for a metal pipe joint for pipe expansion in which metal pipes whose internal diameters in the vicinity of the ends have not been expanded are butted, and are diffusion bonded under bonding conditions such that the junction vicinity laterally expands.

(Claim 9)

The metal pipe joint for pipe expansion according to Claim 8 that is diffusion bonded such that the lateral expansion rate of the junction vicinity is greater than 1.04.

(Detailed Description of the Invention)

(0001)

(Technical Field of the Invention)

The present invention is related to a metal pipe joint for pipe expansion and the manufacturing method thereof; more specifically, it is related to an ideal metal pipe joint for pipe expansion and its manufacturing method used for the plumbing for plants or line piping that is used in the chemical industry or the petrochemical industry, or as the oil well pipe of casing tubes, production tubes, or coiled tubes used in oil wells.

(0002)

(Prior Art)

Conventionally, in fields such as the chemical industry and the petrochemical industry, long metal pipes are used in order to transport corrosive liquids over long distances. For example, pipe lines are for the purpose of transporting crude oil obtained from an oil field to an oil refinery, for example, and their lengths span across tens of kilometers.

(0003)

Furthermore, when digging an oil well, in order to preserve the gallery that was excavated beneath the ground or to prevent crude oil leakage, steel pipes called casing are buried within the gallery. The oil field is normally in a location several thousand meters under ground, so it is necessary that the casing also have the length of several thousand meters.

(0004)

Moreover, seamless steel pipes that are superior with respect to corrosion resistance are generally used for metal pipes that are exposed to a corrosive environment, but the length of industrially mass produced seamless steel pipes is between 10 - 15 m, and the upper limit on the possible manufactured length is approximately 100 m. Accordingly, joints that connect multiple seamless steel pipes of length between 10 - 15 m are used in line piping or oil well pipe such as casing.

(0005)

As a bonding method for metal pipe that is used in such applications, threaded connection methods (mechanical coupling method), welding methods (orbital welding method), and diffusion bonding methods are well known.

(0006)

Furthermore, as for the joints (called "metal pipe joints" hereafter) in which multiple metal pipes that have prescribed length are united, it is typical for them to be used as they are, without expanding or reducing the internal diameter. In other words, it is typical for metal pipe joints that have a desired internal diameter to be manufactured by bonding metal pipes that have a desired internal diameter.

(0007)

However, in contrast to line piping that is laid above ground, casing that is used in oil wells is buried beneath the ground, so there are the following problems in using metal pipe joints that have prescribed internal diameters as casings without modification.

(0008)

Stated simply, it is difficult to excavate a bare gallery towards an oil field that is in a location several thousand meters under ground. Therefore, oil well excavation operations sequentially repeat the following operations: (a) the operation of excavating a gallery using a drill pipe that has a bit that is mounted on its tip, (b) the operation of burying casing at a location in which digging has advanced to a certain extent in order to protect the gallery, and (c) the operation of pouring cement between the buried casing and the stratum, and stabilizing the casing. As a result, oil wells have a structure in which multiple casing is overlapped in a nested form.

(0009)

The structure of a typical oil well is shown in Figure 6. Oil well 10 that is illustrated in Figure 6 is equipped with conductor pipe 12 that has a maximum external diameter for the purpose of protecting the gallery wall in the vicinity of the surface of the earth, surface casing 14 that is sequentially inserted in a nested form into conductor pipe 12, intermediate casing 16, and four production casings 18 of maximum length that reach oil stratum 20.

(0010)

However, when burying the next casing (called "inner side casing" hereafter) inside the gallery through the hole in the center of the casing that was previously buried (called "outer side casing" hereafter), there are cases in which the insertion of the inner side casing becomes difficult because the axis of the inner side casing and the axis of the outer side casing shift out of alignment, or the shape of either the inner side

casing or the outer side casing is irregular. Therefore, it was necessary to make the external diameter of the inner side casing approximately 10 - 30% smaller than the internal diameter of the outer side casing to be on the safe side.

(0011)

Furthermore, the production efficiency of the oil well is dependant on the internal diameter of the production casing that reaches the oil stratum.

Accordingly, in order to secure prescribed production efficiency, it is necessary not only to give the internal diameter of the production casing a prescribed size, but also to enlarge the internal diameter of the casing that was previously buried. Therefore, the necessity to enlarge the internal diameter of the gallery that is excavated in the vicinity of the surface of the earth arose, and became a factor that increases the cost of oil well drilling.

(0012)

Thereby, in order to solve this problem, a method was disclosed in Published Japanese Translation of a PCT Application H7-507610 that expands the casing in the radial direction with respect to the borehole by burying casing made from malleable materials in the borehole that was excavated under the earth, and expanding a hydraulic expanding tool within the casing.

(0013)

Furthermore, a method was disclosed in International Publication Number WO98/0062 that inserts steel pipe made from a malleable type of metal, which generates strain hardening, into either a gallery or casing that was previously buried without incidence of necking or ductile fracture, and expands casing using a mandrel that has a tapered surface made of a nonmetal material.

(0014)

Through the methods disclosed in Published Japanese Translation of a PCT Application H7-507610 or International Publication Number WO98/0062, it is possible to insert inner side casing that has a relatively small external diameter in comparison to the gallery or outer side casing internal diameter, so there is the advantage that it is possible to smoothly perform the inner side casing insertion operation.

(0015)

Moreover, the expansion of inner side casing that was inserted into a gallery of outer side casing is performed using a hydraulic expansion tool or a mandrel, so there is the advantage that nearly the entire cross sectional area of the gallery can be used for crude oil transportation. Furthermore, because the effective cross sectional area of the gallery becomes large, there is the advantage that it is possible to reduce the internal diameter of the gallery to be excavated, and it is thus possible to cut excavation costs.

(0016)

Furthermore, as disclosed in Published Japanese Translation of a PCT Application H7-507610, in the case in which casing is expanded in the radial direction with respect to the borehole, the casing is maintained by the compressive stress received from the borehole wall, so there is the advantage that the cementing operation becomes unnecessary.

(0017)

(Problems Addressed by the Invention)

However, the entire length of casing that is used in oil wells reaches several thousand meters, so although junctions must necessarily be present, junctions are not taken into consideration in either Published Japanese Translation of a PCT Application H7-507610 or International Publication Number WO98/0062.

(0018)

For example, in the case in which metal pipes are bonded through welding methods or metallurgical bonding methods such as diffusion bonding to form metal pipe joints, heat-affected zones generate at the time of bonding in the vicinity of the junctions, so there are cases in which the deformability decreases. Therefore, in the case in which the obtained metal pipe joints are expanded as they are using a mandrel, for example, there is the problem in which there is a danger that fissures will generate in the junctions.

(0019)

Moreover, in the case in which metal pipe is bonded through a threaded connection method to form a metal pipe joint and this is expanded with a mandrel, for example, there is the problem that the thread portion

becomes loose due to plastic-deformation at the time of expansion and the airtightness of the junction decreases.

(0020)

Furthermore, the threaded connection method normally forms outer thread 1a and 2b on the ends of metal pipes 1 and 2 as shown in Figure 7, and unites metal pipes 1 and 2 through coupling 7 that has internal thread 7a that can screw into this external thread 1a and 2b. Accordingly, the vicinity of the junction becomes more thick-walled than the non-conjugative regions, so in the case in which such a metal pipe joint is expanded using a mandrel, for example, there is the problem in which the deformation resistance of the junction becomes large and the expansion operation cannot be performed smoothly.

(0021)

Moreover, in the case in which a metal pipe joint with length of several thousand meters that has a uniform internal diameter is expanded at once using a mandrel, the mandrel constantly receives a reactive force from the metal pipe joint at the time of the pipe expansion, so a large motive energy becomes necessary to move the mandrel.

(0022)

In order to solve this problem, a point is disclosed in International Publication Number WO98/0062, for example, in which the frictional force that generates between the mandrel and the casing is reduced by constructing the tapered surface of the mandrel with a nonmetal material such as zirconia, but there is no change in the fact that the mandrel continuously receives a constant reactive force from the casing during pipe expansion, and it is insufficient with respect to motive energy conservation.

(0023)

Furthermore, as disclosed in Published Japanese Translation of a PCT Application H7-507610, it is possible to conserve motive energy in comparison to the case in which the mandrel is expanded all at once by repeating the following process: retain the hydraulic expansion tool in a location within the casing, expand the hydraulic expansion tool and expand only the casing that is in that position, and then move it to the upper region after contracting the hydraulic tool. However, this results in expanding the casing in a multistage manner, so there is the drawback that the operation efficiency is poor.

(0024)

Moreover, in the case in which the metal pipe is bonded using a diffusion bonding method, it is typical to evenly process only the end face of the metal pipe and use it for bonding without adjusting the periphery surface and the wall thickness. However, in industrially mass produced metal pipes, there is a prescribed dimensional tolerance, and the external diameters and wall thickness of each metal pipe vary within the range of the dimensional tolerance.

(0025)

Therefore, in the case in which mass produced metal pipes are used as they are in diffusion bonding, there is the danger that level differences will arise in the junctions of the metal pipe joints that are obtained. Stress tends to concentrate in level differences that generate in the junctions, so in the case in which such metal pipe joints are expanded, there is the danger that fissures will generate from the regions of level differences. Furthermore, because the level differences remain in the junctions even after pipe expansion, there is the danger that fatigue characteristics and corrosion resistance will diminish due to stress concentration or the retention of corrosive substances. However, nothing is disclosed in the aforementioned prior art literature regarding specific means to solving such problems.

(0026)

A problem addressed by the present invention is to provide a metal pipe joint for pipe expansion and its manufacturing method in which (a) fissures do not generate in the junction, even if pipe expansion is performed, and (b) there is no reduction in the airtightness of the junction that originates from the loosening of thread.

(0027)

Furthermore, another problem addressed by the present invention is to provide a metal pipe joint for pipe expansion and its manufacturing method, in which (a) the deformation resistance at the time of pipe expansion is small and (b) motive energy conservation in the pipe expansion operation is possible.

(0028)

Furthermore, another problem addressed by the present invention is to provide a metal pipe joint for pipe expansion and its manufacturing method, in which (a) the level differences that arise in the junctions are small, and (b) is superior with respect to strength, fatigue characteristics, and corrosion resistance.

(0029)

(Means for Solving the Problems)

In order to solve the aforementioned problems, the metal pipe joint for pipe expansion of the present invention can be summarized in that it is a metal pipe joint in which multiple metal pipes have been bonded, and the internal diameters of the junctions are larger than the internal diameters of the non-conjugative regions.

(0030)

Specifically, such a metal pipe joint for pipe expansion can be easily manufactured by expanding the internal diameter of the vicinity of the end of the metal pipe in advance, and then bonding like metal pipes to one another. In this case, it is desirable to expand the internal diameter of the vicinity of the end of the metal pipe such that the end diameter expansion rate is greater than 5%. If the end diameter expansion rate is less than 5%, then there is the danger that fissures will generate from the junctions when performing pipe expansion, so this is undesirable. Moreover, in this case, a diffusion bonding method or an arc welding method would be ideal as a bonding method.

(0031)

Moreover, a metal pipe joint such as that described above can also be manufactured by expanding the internal diameter in the vicinity of the end of the metal pipe, forming thread on the end of the metal pipe, and mechanically fastening like metal pipes to one another with the thread. In this case, it is desirable to expand the internal diameter of the vicinity of the end of the metal pipe such that the end diameter expansion rate is greater than 10%. If the end diameter expansion rate is less than 10%, the thread regions plastic-deform and the airtightness of the thread regions decreases, so this is undesirable.

(0032)

Furthermore, a metal pipe joint such as that described above can also be manufactured by butting metal pipes whose internal diameters in the vicinity of the end have not been expanded, and diffusion bonding them under bonding conditions such that the junction vicinity laterally expands. In this case, it is desirable to perform diffusion bonding such that the lateral expansion rate in the junction vicinity is greater than 1.04%. If the lateral expansion rate is less than 1.04%, there is the danger that fissures will generate from the junctions when performing pipe expansion, so this is undesirable.

(0033)

As for the metal pipe joint for pipe expansion of the present invention that has the configuration described above, the internal diameters of the junctions are larger than the internal diameters of the non-conjugative regions, so in the case in which such a metal pipe joint for pipe expansion is expanded using a mandrel, for example, it is possible to restrain the plastic stress of the junctions such that it is less than the plastic stress of the non-conjugative regions.

(0034)

Therefore, it becomes difficult for fissures to generate in the junctions due to pipe expansion, even in the case in which, for example, when metal pipe whose end internal diameters have been expanded at a prescribed end diameter expansion rate are bonded through diffusion bonding or welding methods and the obtained metal pipe joint is expanded, heat-affected zones generate in the vicinity of the bonding boundaries and the deformability in the vicinity of the bonding boundaries is diminished.

(0035)

Moreover, if metal pipes whose end internal diameters have not been expanded are butted, a metal pipe joint is formed by plastic-deforming the junction into a barrel shape at a prescribed lateral expansion rate with the pressure at the time of diffusion bonding, and this is expanded; then not only is the generation of fissures in the junction restrained, but there is also the advantage that the process of expanding the end internal diameters of the metal pipes becomes unnecessary.

(0036)

Furthermore, in the case in which a metal pipe joint is formed by using a threaded connection method to bond metal pipes whose end internal diameters have been expanded at a prescribed end diameter expansion rate, if the metal pipe joint is expanded such that the pipe expansion rate is less than the end diameter expansion rate, then there is to be no incidence of plastic-deformation of the junction. Therefore, there is no decrease in airtightness, which originates from the loosening of thread.

(0037)

Moreover, in the metal pipe joint for pipe expansion of the present invention, the internal diameters in the junction vicinity are greater than the internal diameters of the non-conjugative regions, so the deformation resistance in the junction vicinity becomes small. Therefore, it is possible to perform the pipe expansion operation smoothly, and the motive energy in the pipe expansion operation is also conserved.

(0038)

Furthermore, in the case in which a metal pipe joint is formed by expanding the ends of the metal pipes at a prescribed end diameter expansion rate in advance and bonding the expanded metal pipes, it is possible to at least align each of the metal pipes through diameter expansion. Therefore, even in the case in which a metal pipe joint is manufactured using metal pipes in which the external diameters or wall thicknesses vary within a prescribed dimensional tolerance, it is possible to reduce the level differences that generate on the inside surface of the junction, and it becomes possible to obtain a metal pipe junction that is superior with respect to strength, fatigue characteristics, and corrosion resistance.

(0039)

(Embodiments of the Invention)

Embodiments of the present invention will be explained in detail below with reference to the drawings. Figure 1 is a flow chart that shows manufacturing method (called "method A" hereafter) for the metal pipe joint for pipe expansion of the first embodiment of the present invention. In Figure 1, method A comprises a diameter expansion process, an end face finishing process, and a diffusion bonding process.

(0040)

First, the diameter expansion process will be explained. The diameter expansion process in which only the internal diameters of both ends inside cylindrical metal pipe 30 as shown in Figure 1 (a) are enlarged using an appropriate industrial tool, and metal pipe 30, in which the internal diameter d_1 of the end has become greater than the internal diameter d_0 in the center, is processed as shown in Figure 1 (b).

(0041)

Here, as for the metal pipe 30 that is used in the present invention, there are no particular restrictions regarding material quality or dimensions as long as it is of a material that has deformability that can withstand the pipe expansion described later. For example, in metal pipe joints that are used in applications in which only mechanical characteristics are required, it is possible to use carbon steel for metal pipe 30.

Moreover, in applications in which both strength and corrosion resistance of line pipes or oil well pipes are required, for example, it is possible to use stainless steels such as martensitic stainless steel, two-phase stainless steel, or austenitic stainless steel, or Ti alloy.

(0042)

Moreover, in the present invention, the increment of the internal diameter of metal pipe 30 after expansion with respect to the minimum value of the internal diameter of each metal pipe 30 prior to expansion is called the end diameter expansion rate, and it is defined by the following Formula 1.

(0043)

(Formula 1)

End diameter expansion rate (%) = $(d_1 - d_{0 \text{ min}}) \times 100 / d_{0 \text{ min}}$

Where:

d_1 : internal diameter of the end of metal pipe 30 after expansion

$d_{0 \text{ min}}$: minimum value of the internal diameter of the end of metal pipe 30 prior to expansion

(0044)

In the case of method A, it is desirable for the end diameter expansion rate to be greater than 5%. If the end diameter expansion rate is less than 5%, then the necessity to greatly plastic-deform the junctions arises in the pipe expansion process explained later, and there is the danger that fissures will generate in the junctions, so this is undesirable. Moreover, if the end diameter expansion rate is less than 5%, there are cases in which large level differences generate in the junctions due to the dimensional accuracy of each metal pipe 30, and the fatigue strength diminishes, so this is also undesirable.

(0045)

This is because, if the end diameter expansion rate is less than 5% in the case in which the internal diameter of metal pipe 30 varies within a prescribed dimensional tolerance, there is the danger that only metal pipes whose internal diameter d_0 prior to expansion is smaller than the internal diameter d_1 after expansion will be expanded, and metal pipes that have internal diameters greater than d_1 will not be expanded.

(0046)

Also, as the minimum value $d_{0 \text{ min}}$ of the internal diameter that is used to calculate the end diameter expansion rate, from the perspective of allowing for safety it is desirable to use the minimum value anticipated from the specifications of the metal pipe used in bonding, but it would also be acceptable to use an actual measurement.

(0047)

Moreover, from the perspective of reducing plastic-deformation in the junctions and restraining the generation of fissures, the larger the end diameter expansion rate is the better. Therefore, in accordance with the simplicity of the processing of metal pipe 30 and the applications of the metal pipe joint that is obtained, diameter expansion should be performed with the ideal end diameter expansion rate within a range below the pipe expansion rate described later.

(0048)

Moreover, the length (called "diameter expansion length" hereafter, represented by " L_1 " within Figure 1 (b)) of the portion in which the internal diameter was enlarged through diameter expansion may be arbitrarily chosen with consideration on the simplicity of processing of metal pipe 30 and the applications, but from the perspective of reducing deformation resistance in the pipe expansion process described later and conserving motive energy in the pipe expansion operation, the longer it is the better.

(0049)

Furthermore, there are no particular restrictions on the diameter expansion method either, and it is possible to use various methods. Normally, a mandrel or a plug that has an external diameter corresponding to d_1

that is expressed in Formula 1 should be inserted into the end of metal pipe 30 up to a prescribed length, and the end internal diameter should then be expanded.

(0050)

Next, the end face finishing process will be explained. The end face finishing process is a process in which, as shown in Figure 1 (c), the end face of metal tube 30, whose end internal diameter was expanded through the diameter expansion process, is machine finished to a prescribed surface roughness. This is because, if the surface texture of the end face of metal pipe 30 is rough, then the bonding boundaries will not sufficiently adhere and high bond strength will not be obtained in the diffusion bonding process described later.

(0051)

Also, there are no particular restrictions regarding the end surface finishing method, and various methods such as grinding or lapping can be used. Moreover, in the case in which the surface roughness of the end face of metal pipe 30 is held within a prescribed range even after diameter expansion, the end face finishing process is not absolutely necessary, and it can be omitted.

(0052)

Next, the diffusion bonding process will be explained. The diffusion bonding process is a process in which metal pipes 30, whose end internal diameters were expanded in the diameter expansion process and whose end faces were finished to a prescribed surface roughness in the end face finishing process, are butted and like metal pipes 30 are diffusion bonded to one another.

(0053)

Here, as for the diffusion bonding method, there is (a) solid phase diffusion bonding that directly butts metal pipes 30 and diffuses elements while maintaining them in the solid phase, and (b) liquid phase diffusion bonding that places an insert material onto the bonding boundary and diffuses elements while temporarily melting the insert material, and either method may be used.

(0054)

In particular, with liquid phase diffusion bonding, joints that have strength that is equivalent to that of the parent material can be obtained in a short period of time in comparison to solid phase diffusion bonding, so it is ideal as a bonding method. One example of metal pipe joint 32 that is bonded through liquid phase diffusion bonding by placing insert material 36 on the bonding boundary of metal pipes 30 and 30 is shown in Figure 1 (d).

(0055)

Moreover, as for the conditions for diffusion bonding, an ideal range should be chosen according to the material of the metal pipe 30 that is used. Specifically, it should be performed under the following conditions.

(0056)

First, it is preferable for the surface roughness R_{max} of the bonding surface to be less than $50 \mu m$. If the surface roughness R_{max} of the bonding surface exceeds $50 \mu m$, like metal pipes 30 will not sufficiently adhere at the bonding surface and high bonding strength will not be obtained, so this is not desirable. From the perspective of obtaining high bonding strength, the smaller the surface roughness R_{max} is the better.

(0057)

Moreover, as for the insert material 36 that is used, a Ni-family alloy or Fe-family alloy that has a melting point that is less than $1200^{\circ}C$ is ideal. If the melting point of insert material 36 exceeds $1200^{\circ}C$, a high bonding temperature will become necessary, which is undesirable because the parent material will be melted during bonding, or unbonded portions will generate because insert material 36 is not melted.

(0058)

Furthermore, the thickness of the insert material 36 that is used is preferably less than 100 μm . If the thickness of the insert material 36 exceeds 100 μm , the diffusion of elements at the bonding boundary will not be sufficiently performed and the bonding strength will diminish, so this is undesirable.

(0059)

Also, there are no particular restrictions regarding the shape of insert material 36,

and an insert material 36 made of foil with thickness less than 100 μm may be placed on the bonding boundary. Alternatively, it would also be acceptable to disseminate a powder or squamation insert material 36 on the bonding boundary, or to make it into a paste and apply it to the bonding boundary in order to bring the thickness to less than 100 μm .

(0060)

A non-oxidizing atmosphere is preferable for the bonding atmosphere. If bonding is conducted under an oxidizing atmosphere, the bonding boundary vicinity will oxidize and the bonding strength will diminish, so this is undesirable.

(0061)

It is ideal for the bonding temperature to be within a range that is greater than 1250°C and less than 1400°C. If the bonding temperature is less than 1250°C, portions of insert material 36 will not melt, or the diffusion of elements will not be conducted sufficiently, causing the bonding strength to diminish, so this is undesirable. Moreover, if the bonding temperature is greater than 1400°C, there is the danger that the parent material will melt, so this is not desirable.

(0062)

It is ideal for the retention time of the bonding temperature to be greater than 30 seconds and less than 300 seconds. If the retention time is less than 30 seconds, the diffusion of elements on the bonding boundary will become insufficient and the bonding strength will diminish, so this is undesirable. Moreover, the operation efficiency will diminish if the retention time is greater than 300 seconds, so this is also undesirable.

(0063)

Furthermore, it is ideal for the pressure that is applied to the bonding boundary to be greater than 1.5 MPa and less than 5 MPa. If the applied pressure is less than 1.5 MPa, the adherence of the bonding boundary will become insufficient and the bonding strength will diminish, so this is undesirable.

(0064)

Moreover, in method A, pipe expansion of the metal pipe joint is performed in the pipe expansion process described later after the metal pipes are bonded, so it would be acceptable for the junction vicinity to slightly deform after bonding. However, if the sum of the increment of the internal diameter in the diameter expansion process and the increment of the internal diameter that originates from deformation at the time of bonding exceeds the pipe expansion rate in the pipe expansion process described later, then irregularities will remain in the vicinity of the bonding boundary even after pipe expansion, which becomes a cause for the reduction of bonding strength. Accordingly, in method A, it is ideal to configure the applied pressure to less than 5 MPa such that the junction vicinity does not excessively deform.

(0065)

Moreover, as a heating method when performing diffusion bonding, it is possible to use various methods such as high frequency induction heating, high frequency direct conduction heating, or resistance heating. Among these, with high frequency induction heating and high frequency direct conduction heating, it is possible to easily heat even with a relatively large material to be bonded, the heating efficiency is high, and it is possible to heat to the bonding temperature in an extremely short amount of time, so they are particularly suitable as heating methods.

(0066)

However, as for the high frequency current that is used in high frequency induction heating or high frequency direct conduction heating, it is ideal to use a current that has frequency less than 100 kHz. If the frequency exceeds 100 kHz, only the surface will be heated due to the skin effect and the entire bonding surface will not be heated uniformly, so this is undesirable.

(0067)

Next, the pipe expansion process for the metal pipe joint for pipe expansion that was obtained in this way will be explained. The pipe expansion process is a process in which pipe expansion is performed on the metal pipe joint 32 that was manufactured in the diameter expansion process, end face finishing process, and the diffusion bonding process described above, and the internal diameter of metal pipe joint 32 is set to a uniform size.

(0068)

Specifically, mandrel 34 is inserted as shown in Figure 2 (a) from one end of metal pipe joint 32 whose internal diameters of the junctions and non-conjugative regions are respectively d_1 and d_0 , mandrel 34 is moved towards the other end of metal pipe joint 32 as shown in Figure 2 (b), and the internal diameter of metal pipe joint 32 is enlarged to d_2 . In the present invention, the increment of the internal diameter after pipe expansion with respect to the minimum value of the internal diameter of the non-conjugative regions prior to pipe expansion is called the pipe expansion rate, and it is defined by the following Formula 2.

(0069)

(Formula 2)

Pipe expansion rate (%) = $(d_2 - d_{0 \min}) \times 100 / d_{0 \min}$

Where:

d_2 : internal diameters of the non-conjugative regions after pipe expansion

$d_{0 \min}$: minimum value of the internal diameters of the non-conjugative regions prior to pipe expansion

(0070)

Also, in the case of method A, the pipe expansion rate may be arbitrarily chosen with consideration on the deformability of metal pipe 30 and the application of metal pipe joint 32. Moreover, if the bonding conditions are appropriate, it is possible to highly maintain the deformability of the junction vicinity, so it is also possible to expand with a pipe expansion rate that is larger than the end diameter expansion rate. Furthermore, it would be acceptable to use the minimum expected value from the specifications as the minimum value $d_{0 \min}$ of the internal diameter of the non-conjugative regions prior to pipe expansion, and the fact that an actual measurement may also be used is the same as for Formula 1.

(0071)

Next, the effects of method A will be explained. If the diameters of the ends of metal pipes 30 (Figure 1 (a)) that have prescribed length and internal diameter are expanded with a prescribed end diameter expansion rate and a prescribed diameter expansion length L_1 (Figure 1 (b)), and like metal pipes 30 are diffusion bonded to one another after the end faces are machine finished to a prescribed surface roughness (Figure 1 (c)), then it is possible to obtain metal pipe joint 32 in which the internal diameters d_1 of the junctions have become larger than the internal diameters d_0 of the non-conjugative regions as shown in Figure 1 (d).

(0072)

If mandrel 34 is inserted into one end of such a metal pipe joint 32 and mandrel 34 is moved towards the other end, then the internal diameter of metal pipe joint 32 enlarges, and it is possible to obtain metal pipe joint 32 that has a constant internal diameter d_2 as shown in Figure 2 (b).

(0073)

At this time, the internal diameter d_1 of the junction prior to pipe expansion has become greater than the internal diameters d_0 of the non-conjugative regions, so the plastic stress of the junction at the time of pipe expansion becomes smaller than the plastic stress of the non-conjugative regions. Therefore, it becomes difficult for fissures to generate in the junction due to pipe expansion, even in the case in which heat-affected zones generate at the time of diffusion bonding and the deformability of the junction diminishes.

(0074)

Moreover, because the internal diameter d_1 of the junction is larger than the internal diameter d_0 of non-conjugative regions, the deformation resistance in the junction vicinity becomes small. The quantity of diminution becomes larger as the internal diameter d_1 of the junction becomes larger or the diameter expansion length L_1 becomes longer. Therefore, the sum of the frictional resistance that mandrel 34

receives at the time of pipe expansion becomes small in comparison to the case in which a metal pipe joint that has a uniform internal diameter is expanded, and motive energy is conserved in the pipe expansion operation.

(0075)

Furthermore, even in the case in which the exterior diameters and wall thicknesses of each metal pipe 30 vary within the dimensional tolerance, if the internal diameters in the end vicinity of metal pipes 30 are expanded and they are bonded after the internal diameters of all of the metal pipes 30 are aligned, then it is possible to reduce the level differences that generate on the inner periphery side of the junction of metal pipe joint 32. Therefore, with such a metal pipe joint 32, the danger that fissures that originate from level differences in the junction will generate is small, even if pipe expansion is performed. Moreover, stress concentration and the retention of corrosive substances become unlikely, so the strength, fatigue characteristics, and corrosion resistance of metal pipe joint 32 that was expanded will not diminish.

(0076)

Also, a diffusion bonding method is used as the bonding method in method A described above, but it would also be acceptable to use an arc welding method, and through this it would be possible to obtain the same results (called "method A" hereafter). In this case, the internal diameters of the end vicinity of metal pipes 30 are expanded with a prescribed end diameter expansion rate in the diameter expansion process, grooves are formed on metal pipes 30 in the end face finishing process, and these are butted and molten metal is clad in the grooves.

(0077)

Next, the manufacturing method of the metal pipe joint for pipe expansion of the second embodiment of the present invention will be explained. Figure 3 is a flow chart that shows the manufacturing method (called "method B" hereafter) of the metal pipe joint for pipe expansion of the second embodiment of the present invention. In Figure 3, method B comprises a diameter expansion process, a thread working process, and a fastening process.

(0078)

The diameter expansion process is a process in which, in the same manner as method A explained above, by enlarging only the internal diameter of the end vicinity within cylindrical metal pipe 40 as shown in Figure 3 (a) using an appropriate industrial tool, the metal pipe 40, in which the internal diameter of the end vicinity has been expanded at a prescribed end diameter expansion rate, is processed as shown in Figure 3 (b).

(0079)

However, in the case of method B, it is desirable for the end diameter expansion rate to be greater than 10%. If the end diameter expansion rate is less than 10%, the necessity to greatly plastic-deform the junctions in the pipe expansion process described later will arise, and if junctions that have been fastened through threaded connection methods are plastic-deformed, the thread will become loose and the airtightness will diminish, so this is undesirable.

(0080)

Also, (a) the fact that any material that has deformability that can withstand the pipe expansion can be used for metal pipe 40, (b) the fact that the expansion length L_1 can be arbitrarily chosen with consideration on simplicity of processing of metal pipe 40, and (c) the fact that various methods can be used for the diameter expansion method are all the same as method A described above.

(0081)

Next, in the thread working process, external thread 40a is formed on the end of metal pipe 40 whose end internal diameter was expanded in the diameter expansion process, as shown in Figure 3 (c). Also, in the case of threaded connection methods, the load that can support the junctions is dependant upon the length L_2 of the thread, so it is possible to arbitrarily establish thread length L_2 according to the characteristics required by metal pipe joint 42.

(0082)

Next, the fastening process is a process in which like metal pipes 40, whose end internal diameters were expanded in the diameter expansion process and external thread 40a was established on the ends in the thread working process, are fastened to one another using coupling 44. Internal thread 44a that can screw into external thread 40a that was formed on metal pipes 40 is formed on coupling 44. Metal pipe joint 42 that was obtained in this way is shown in Figure 3 (d).

(0083)

The manufactured metal pipe joint 42 is expanded in the same manner as with metal pipe joint 32 that was obtained through method A, and the internal diameter of metal pipe joint 42 is enlarged to the uniform size d_2 . Specifically, mandrel 34 is inserted from one end of metal pipe joint 42 as shown in Figure 4 (a), and the internal diameter of metal pipe joint 42 is expanded with a prescribed pipe expansion rate by moving mandrel 34 towards the other end of metal pipe joint 42, as shown in Figure 4 (b).

(0084)

Here, in the case of method B, it is desirable to perform the pipe expansion of metal pipe joint 42 with a pipe expansion rate that is less than the end diameter expansion rate of metal pipe 40. If the pipe expansion rate exceeds the end diameter expansion rate, there is the danger that the junction will plastic-deform and the threads will become loose at the time of pipe expansion, so this is undesirable. Moreover, the junction vicinity is thick-walled because there is the coupling 44. Therefore, expanding pipe with a pipe expansion rate that exceeds the end diameter expansion rate invites the increase of deformation resistance and a smooth pipe expansion operation becomes difficult, so this is undesirable.

(0085)

Next, the effects of method B will be explained. If the internal diameters of the end vicinity of metal pipes 40 are expanded in advance such that the end diameter expansion rate is greater than 10%, and like metal pipes 40 are bonded to one another through a threaded connection method, then it is possible to easily obtain metal pipe joint 42 in which the internal diameter d_1 of the junction has become larger than the internal diameter d_0 of the non-conjugative regions.

(0086)

If metal pipe joint 42 that was obtained in this way is expanded using a mandrel, for example, the deformation resistance of the junction vicinity becomes small in the same manner as with method A. Therefore, motive energy in the pipe expansion operation can be conserved in comparison to the case in which a metal pipe joint that has a uniform internal diameter is expanded. In addition, pipe expansion is performed with a pipe expansion rate that is less than the end diameter expansion rate, so the problem that is specific to threaded connection methods – the decrease of airtightness that originates in the thread plastic-deformation – is solved.

(0087)

Next, the manufacturing method of a metal pipe joint for pipe expansion of the third embodiment of the present invention will be explained. Figure 5 (a) - (c) is a flow chart that shows the manufacturing method of a metal pipe joint for pipe expansion of the third embodiment of the present invention (called "method C" hereafter).

(0088)

In the case of method C, the fact that any material that has deformability that can withstand the pipe expansion can be used for metal pipe 50 is the same as with method A. However, it differs from method A in that the ends of cylindrical metal pipes 50 are not expanded, but rather diffusion bonding is performed as they are, and the junction vicinity is deformed into a barrel shape at the time of diffusion bonding.

(0089)

Stated simply, the diameter of the end of cylindrical metal pipe 50 such as that shown in Figure 5 (a) is not expanded,

but instead they are butted and pressurized as they are (Figure 5 (b)), and the junction vicinity is heated through heat source 54. Also, as for the bonding method, a liquid phase diffusion bonding method that performs bonding by placing insert material 36 on the bonding boundary as shown in Figure 5 (b) may be used, or a solid phase diffusion bonding method that does not use insert material 36 may also be used.

(0090)

At this time, if the bonding conditions are appropriate, the bonding boundary vicinity is deformed into a barrel shape at the same time that diffusion bonding progresses on the bonding boundary, and it is possible to obtain metal pipe joint 52 in which the internal diameter $d_{(3)}$ of the junction has become larger than the internal diameter d_0 of the non-conjugative regions as in Figure 5 (c). In the present invention, the increment of the internal diameter of the junction after diffusion bonding with respect to the minimum value of the internal diameter of the non-conjugative regions of the metal pipe is called the lateral expansion rate, and it is defined by the following Formula 3.

(0091)

(Formula 3)

Lateral expansion rate = $d_3/d_{0 \min}$

Where:

d_3 : Internal diameter of the junction

$d_{0 \min}$: Minimum value of the internal diameter of the non-conjugative regions

(0092)

In the case of method C, it is desirable for the lateral expansion rate to be greater than 1.04. If the lateral expansion rate is less than 1.04, there is the danger that the necessity to greatly plastic-deform the junction will arise in the pipe expansion process described later and fissures will generate in the junction, so this is undesirable.

(0093)

Also, it would be acceptable to use the minimum expected value from the specifications as the minimum value $d_{0 \min}$ of the internal diameter of the non-conjugative regions, and the fact that an actual measurement may also be used is the same as for Formula 1. Moreover, from the perspective reducing the plastic stress of the junction at the time of pipe expansion and restricting the generation of fissures, the larger the lateral expansion rate is the better. Furthermore, from the perspective of making the deformation resistance small in the pipe expansion process, the longer the length (called the "expansion length" hereafter, expressed by " L_3 " within Figure 5 (c)) of the portion whose internal diameter was increased through diffusion bonding is the better.

(0094)

Moreover, in the case of method C, it is necessary to actively plastic-deform the bonding boundary vicinity at the time of diffusion bonding, so with regard to the diffusion bonding conditions, it is necessary to select conditions obtained from the required lateral expansion rate, for example. Specifically, bonding should be performed under the following conditions.

(0095)

Simply stated, it is ideal for the bonding temperature to be within a range that is greater than 1250°C and less than 1400°C. If the bonding temperature is less than 1250°C, portions of insert material 36 will not melt, or the diffusion of elements will not be conducted sufficiently, causing the bonding strength to diminish. Moreover, if the bonding temperature is too low, the deformation resistance of metal pipe 50 will become large and the prescribed lateral expansion rate will not be obtained, so this is undesirable. Furthermore, if the bonding temperature is greater than 1400°C, there is the danger that the parent material will melt, so this is also undesirable.

(0096)

It is ideal for the retention time of the bonding temperature to be greater than 60 seconds. If the retention time is less than 60 seconds, it will not be possible to obtain a large lateral expansion rate, so this is undesirable. Also, from the perspective of making the lateral expansion rate large, the longer the retention time is the better, so the retention time should be adjusted such that the prescribed lateral expansion rate is obtained.

(0097)

Moreover, it is ideal for the pressure that is applied to the bonding boundary to be greater than 2 MPa. If the applied pressure is less than 2 MPa, it will not be possible to obtain a large lateral expansion rate, so this is undesirable. Also, in the case of method C, from the perspective of making the lateral expansion rate large, the greater the applied pressure is the better, and it may even be greater than 5 MPa. However, if the lateral expansion rate exceeds the pipe expansion rate, irregularities will remain in the bonding boundary vicinity even after pipe expansion, and the bonding strength will diminish. Accordingly, it is desirable to adjust the applied pressure such that the lateral expansion rate is less than the pipe expansion rate.

(0098)

Furthermore, it is desirable for the heating width of the junction vicinity to be greater than 20 mm. If the heating width is less than 20 mm, the lateral expansion rate will become small and the expansion length L_3 will become short, so this is undesirable. From the perspective of making the deformation resistance at the time of pipe expansion small, the larger the lateral expansion rate and the longer the expansion length L_3 is the better, and therefore, it is better for the heating width to be long.

(0099)

Also, (a) the fact that it is desirable for the surface roughness R_{max} of the bonding surface to be less than $50 \mu\text{m}$, (b) the fact that a Ni-family alloy or an Fe-family alloy of thickness less than $100 \mu\text{m}$ whose melting point is less than 1200°C is preferable, and (c) the fact that there are no particular restrictions with regard to the shaped of insert material, and it is possible to use a foil, a powder, or a squamation insert material are all the same as with method A.

(0100)

Moreover, (a) the fact that a non-oxidizing atmosphere is preferable for the bonding atmosphere, and (b) the fact that high frequency induction heating or high frequency direct conduction heating that uses a high frequency current with a frequency less than 100 kHz is preferable for the heat source when performing diffusion bonding are also both the same as with method A.

(0101)

Next, pipe expansion is performed on metal pipe joint 52 that was manufactured as described above and has a prescribed lateral expansion rate. Specifically, mandrel 34 is inserted from one end of metal pipe joint 52 as shown in Figure 5 (d), and mandrel 34 is then moved towards the other end of metal pipe joint 52.

(0102)

Also, (a) the fact that the pipe expansion rate may be arbitrarily chosen with consideration upon the deformability of metal pipe 50 and the application of metal pipe joint 52, and (b) the fact that it is possible to highly maintain the deformability of the junction vicinity if the bonding conditions are appropriate, so it is possible to perform pipe expansion with a pipe expansion rate that is greater than the end diameter expansion rate are both the same as with method A.

(0103)

Next, the effects of method C will be explained. If metal pipes 50 whose end internal diameters have not been expanded are butted, and the junction vicinity is actively plastic-deformed while like metal pipes 50 are diffusion bonded to one another, then it is possible to easily obtain metal pipe joint 52 in which the internal diameter d_3 of the junction has become larger than the internal diameter d_0 of the non-conjugative regions.

(0104)

If a metal pipe joint 52 that was obtained in this way is expanded using a mandrel for example, the deformation resistance of the junction vicinity becomes small in the same manner as with method A. Therefore, in comparison to the case in which a metal pipe joint that has a uniform internal diameter is expanded,

it is possible to perform the pipe expansion operation smoothly, and it is also possible to conserve motive energy in the pipe expansion operation.

(0105)

Moreover, because the internal diameter of the junction has become larger, it is possible to reduce the plastic stress of the junction at the time of pipe expansion. Therefore, as with method A, even in the case in which heat-affected regions generate in the junction vicinity and the deformability is diminished, the generation of fissures in the junction due to pipe expansion becomes unlikely, and it is possible to obtain a metal pipe joint that is superior with respect to strength and airtightness.

(0106)

(Embodiment 1)

Pipe expansion was performed on a metal pipe joint using method A. A carbon steel pipe made from American Petroleum Institution Grade H40 (this is notated as "API H40" hereafter) with an external diameter of 7 inches (178 mm) and wall thickness 0.231 inches (6 mm) was used for the metal pipe, and the end internal diameter of this steel pipe was expanded such that the end diameter expansion rate was 5%.

(0107)

Next, the end face of the expanded metal pipe was finished such that the surface roughness R_{max} is less than $30 \mu\text{m}$, a Ni-family alloy foil with melting point of 1050°C and thickness of $50 \mu\text{m}$ that has a composition equivalent to JIS BNi-3 was placed on the bonding boundary of the metal pipe, and liquid phase diffusion bonding was performed. Furthermore, the obtained metal pipe joint was expanded using a mandrel such that the pipe expansion rate was 25%.

(0108)

Also, a high frequency induction heating method that uses a high frequency current with a frequency of 3 kHz was used as the heating method for the junction. Moreover, the bonding conditions were such that the bonding temperature was 1300°C , the retention time was 180 seconds, and the applied pressure was 4 MPa, and bonding was performed in an Ar atmosphere.

(0109)

(Embodiments 2 - 3, Comparative Examples 1, 2)

Apart from respectively setting the end diameter expansion rates of metal pipes 30 to 0% (Comparative Example 1), 3% (Comparative Example 2), 20% (Embodiment 2), and 25% (Embodiment 3), the manufacturing and expansion of the metal pipe joints were performed in accordance with the same procedures as with Embodiment 1.

(0110)

With respect to the metal pipe joints that were obtained in Embodiments 1 - 3 and Comparative Examples 1 - 2, the maximum value of the level differences that generated on the inner periphery side of the junctions after bonding (this is simply called the "maximum level difference" hereafter) was measured. Moreover, a penetrant test was performed with respect to the junction surface after pipe expansion, and the presence of cracks was investigated. Furthermore, after the level differences alone that generated on the external periphery of the expanded joint were grinded with a grinder and set to less than 0.5 mm, an API 1104 specimen was extracted from this joint and tensile tests were conducted. The results are shown in Table 1.

(0111)

(Table 1)

[see source for numbers and English]

Test Number		Comparative Example 1	Comparative Example 2	Embodiment 1	Embodiment 2	Embodiment 3
Steel Pipe	Material					
	Dimensions	External Diameter (Inches)				
		Wall Thickness (Inches)				
End Diameter Expansion Rate (%)						
Bonding Surface Roughness (Rmax: μm)						
Insert Material	Material					
	Melting Point ($^{\circ}\text{C}$)					
	Thickness (μm)					
	Form		Foil	Foil	Foil	Foil
Bonding Temperature ($^{\circ}\text{C}$)						
Retention Time (s)						
Applied Pressure (MPa)						
Bonding Atmosphere						
Heating Method for the Junction		High Frequency Induction Heating Method (3 kHz)	High Frequency Induction Heating Method (3 kHz)	High Frequency Induction Heating Method (3 kHz)	High Frequency Induction Heating Method (3 kHz)	High Frequency Induction Heating Method (3 kHz)
Maximum Level Difference of the Junction (mm)						
Pipe Expansion Rate (%)						
Results of Junction Surface Penetrant Test		Cracks Present	Cracks Present	No Cracks	No Cracks	No Cracks
Tensile Test Results	Tensile Strength (MPa)					
	Break Location	Bonding Boundary	Bonding Boundary	Parent Material	Parent Material	Parent Material
Comprehensive Evaluation						

(0112)

In Comparative Example 1 in which the end diameter expansion rate was taken to be 0%, the maximum level difference reached 4 mm. Moreover, multiple fissures were recognized in the penetrant test after pipe expansion. Furthermore, the tensile strength exhibited low strength of 283 MPa, and the specimen broke away from the bonding boundary.

(0113)

In Comparative Example 2 in which the end diameter expansion rate was taken to be 3%, the maximum level difference fell to 1 mm. Moreover, significant fissures were recognized in the junction in the penetrant test after pipe expansion, but the number of fissures was less than in Comparative Example 1.

Accordingly, the tensile strength improved to 467 MPa, but the specimen broke away from the bonding boundary.

(0114)

In contrast to this, in Embodiments 1, 2, and 3 in which the end diameter expansion rates were respectively taken to be 5%, 20%, and 25%, the maximum level differences all fell to 0.5 mm. Moreover, no fissures were recognized on the bonding boundary in the penetrant tests following pipe expansion in any of the embodiments. Furthermore, the bonding strengths all exhibited strengths greater than 700 MPa, which is equivalent to that of the parent material, and the specimens broke away from the parent material side.

(0115)

From the above results, it became clear that if the end internal diameter of the metal pipe is expanded before the metal pipes are bonded such that a value greater than the prescribed end diameter expansion rate is achieved, it is possible to make the maximum level difference small. Moreover, it became clear that the greater the end diameter expansion rate is made, the more difficult it will be for fissures to generate in the junction at the time of pipe expansion, and a metal pipe joint with higher bonding strength can be obtained.

(0116)

(Embodiment 4)

Pipe expansion was performed on a metal pipe joint using method A. A carbon steel pipe made from API H40 with an external diameter of 7 inches (178 mm) and wall thickness 0.231 inches (6 mm) was used for the metal pipe, and the end internal diameter of this steel pipe was expanded such that the end diameter expansion rate was 15%.

(0117)

Next, the end face of the expanded metal pipe was finished such that the surface roughness R_{max} is less than $30 \mu\text{m}$, an Fe-3B-3Si-1C alloy foil with melting point of 1200°C and thickness of $40 \mu\text{m}$ was placed on the bonding boundary of the metal pipe, and liquid phase diffusion bonding was performed. Furthermore, the obtained metal pipe joint was expanded using a mandrel such that the pipe expansion rate was 25%.

(0118)

Also, a high frequency induction heating method that uses a high frequency current with a frequency of 3 kHz was used as the heating method for the junction. Moreover, the bonding conditions were such that the bonding temperature was 1250°C , the retention time was 60 seconds, and the applied pressure was 4 MPa, and bonding was performed in an Ar atmosphere.

(0119)

(Embodiment 5)

A Ni-family alloy foil with a melting point of 1140°C and thickness of $40 \mu\text{m}$ that has a composition equivalent to JIS BNi-5 was used as an insert material, and apart from retaining for 120 seconds at 1300°C , the manufacturing and expansion of the metal pipe joint were performed in accordance with the same procedures as with Embodiment 4.

(0120)

(Embodiment 6)

A Ni-family alloy foil with a melting point of 1140°C and thickness of $40 \mu\text{m}$ that has a composition equivalent to JIS BNi-5 was used as an insert material, and apart from setting the bonding temperature to 1400°C and the retention time to 300 seconds, the manufacturing and expansion of the metal pipe joint were performed in accordance with the same procedures as with Embodiment 4.

(0121)

(Comparative Example 3)

An Fe-2B-1Si alloy foil with a melting point of 1290°C and thickness of $40 \mu\text{m}$ was used as an insert material, and apart from setting the bonding temperature to 1400°C , the retention time to 300 seconds, and the applied pressure to 5 MPa, the manufacturing and expansion of the metal pipe joint were performed in accordance with the same procedures as with Embodiment 4.

(0122)

With respect to the metal pipe joints that were obtained in Embodiments 4 - 6 and Comparative Example 3, maximum level difference tests, penetrant tests, and tensile tests were conducted in accordance with the same procedures as with Embodiment 1. The results are shown in Table 2.

(0123)

(Table 2)

[see source for numbers and English]

Test Number		Comparative Example 3	Embodiment 4	Embodiment 5	Embodiment 6
Steel Pipe	Material				
	Dimensions	External Diameter (Inches)			
		Wall Thickness (Inches)			
End Diameter Expansion Rate (%)					
Bonding Surface Roughness (Rmax: μm)					
Insert Material	Material				
	Melting Point ($^{\circ}\text{C}$)				
	Thickness (μm)				
	Form		Foil	Foil	Foil
Bonding Temperature ($^{\circ}\text{C}$)					
Retention Time (s)					
Applied Pressure (MPa)					
Bonding Atmosphere					
Heating Method for the Junction		High Frequency Induction Heating Method (3 kHz)	High Frequency Induction Heating Method (3 kHz)	High Frequency Induction Heating Method (3 kHz)	High Frequency Induction Heating Method (3 kHz)
Maximum Level Difference of the Junction (mm)					
Pipe Expansion Rate (%)					
Results of Junction Surface Penetrant Test		Cracks Present	No Cracks	No Cracks	No Cracks
Tensile Test Results	Tensile Strength (MPa)				
	Break Location		Bonding Boundary	Parent Material	Parent Material
Comprehensive Evaluation					

(0124)

In Comparative Example 3 in which an insert material with a melting point of 1290°C was used, although the retention time was taken to be 300 seconds, fissures were recognized in the junction in the penetrant test following pipe expansion. Moreover, the tensile strength was 417 MPa and the specimen broke away from the bonding boundary. This is thought to have been because the diffusion of elements is not sufficiently performed on the bonding boundary because the melting point of the insert material is high, and thus the deformability of the bonding boundary vicinity is diminished.

(0125)

In contrast to this, in Embodiment 4 in which an insert material with a melting point of 1200°C was used, and in Embodiments 5 and 6 in which an insert material with a melting point of 1140°C was used, no fissures were recognized on the bonding boundary in the penetrant test following pipe expansion for any of the embodiments. Moreover, the bonding strengths all exhibited strengths greater than 700 MPa, which is equivalent to that of the parent material, and the specimens broke away from the parent material side.

(0126)

Also, all of the end diameter expansion rates of the metal pipes were taken to be 15% in Embodiments 3 - 6 and Comparative Example 3, so all of the maximum level differences were 0.5 mm.

(0127)

From the above results, it became clear that if an insert material with a melting point that is less than 1200°C is used in the case in which metal pipes are liquid phase diffusion bonded, then fissures will not generate on the junction following pipe expansion and metal pipe joints with high bond strength can be obtained.

(0128)

(Embodiment 7)

Pipe expansion was performed on a metal pipe joint using method A. A carbon steel pipe made from API H40 with an external diameter of 7 inches (178 mm) and wall thickness 0.231 inches (6 mm) was used for the metal pipe,

and the end internal diameter of this steel pipe was expanded such that the end diameter expansion rate was 15%.

(0129)

Next, the end face of the expanded metal pipe was finished such that the surface roughness R_{max} is less than $30\ \mu\text{m}$, a squamation Ni-family alloy with a melting point of 1140°C that has a composition equivalent to JIS BNi-5 was placed on the bonding boundary of the metal pipe such that the thickness was $100\ \mu\text{m}$, and liquid phase diffusion bonding was performed. Furthermore, the obtained metal pipe joint was expanded using a mandrel such that the pipe expansion rate was 25%.

(0130)

Also, a high frequency induction heating method that uses a high frequency current with a frequency of 3 kHz was used as the heating method for the junction. Moreover, the bonding conditions were such that the bonding temperature was 1300°C , the retention time was 180 seconds, and the applied pressure was 4 MPa, and bonding was performed in an Ar atmosphere.

(0131)

(Embodiment 8)

A Ni-family alloy powder that has a composition equivalent to JIS BNi-5 was used as an insert material, and this was placed on the bonding boundary of the metal pipe such that the thickness was $30\ \mu\text{m}$. Apart from retaining for 60 seconds at the bonding temperature, the manufacturing and expansion of the metal pipe joint were performed in accordance with the same procedures as with Embodiment 7.

(0132)

(Embodiment 9)

A Ni-family alloy foil with thickness of $40\ \mu\text{m}$ that has a composition equivalent to JIS BNi-5 was used as an insert material, and apart from setting the bonding temperature to 1250°C and the retention time to 60 seconds, the manufacturing and expansion of the metal pipe joint were performed in accordance with the same procedures as with Embodiment 7.

(0133)

(Comparative Example 4)

A Ni-family alloy foil with thickness of $200\ \mu\text{m}$ that has a composition equivalent to JIS BNi-5 was used as an insert material, and apart from setting the bonding temperature to 1400°C and the retention time to 300 seconds, the manufacturing and expansion of the metal pipe joint were performed in accordance with the same procedures as with Embodiment 7.

(0134)

(Comparative Example 5)

A Ni-family alloy foil with thickness of $40\ \mu\text{m}$ that has a composition equivalent to JIS BNi-5 was used as an insert material, and apart from setting the bonding temperature to 1450°C and the retention time to 60 seconds, the manufacturing and expansion of the metal pipe joint were performed in accordance with the same procedures as with Embodiment 7.

(0135)

With respect to the metal pipe joints that were obtained in Embodiments 7 - 9 and Comparative Examples 4 - 5, maximum level difference tests, penetrant tests, and tensile tests were conducted in accordance with the same procedures as with Embodiment 1. The results are shown in Table 3.

(0136)

(Table 3)

[see source for numbers and English]

Test Number		Comparative Example 4	Embodiment 7	Embodiment 8	Embodiment 9	Comparative Example 5
Steel Pipe	Material					
	Dimensions	External Diameter (Inches)				
		Wall Thickness (Inches)				
End Diameter Expansion Rate (%)						
Bonding Surface Roughness (Rmax: μm)						
Insert Material	Material					
	Melting Point ($^{\circ}\text{C}$)					
	Thickness (μm)					
	Form		Foil	Squamation	Powder	Foil
Bonding Temperature ($^{\circ}\text{C}$)						
Retention Time (s)						
Applied Pressure (MPa)						
Bonding Atmosphere						
Heating Method for the Junction		High Frequency Induction Heating Method (3 kHz)	High Frequency Induction Heating Method (3 kHz)	High Frequency Induction Heating Method (3 kHz)	High Frequency Induction Heating Method (3 kHz)	High Frequency Induction Heating Method (3 kHz)
Maximum Level Difference of the Junction (mm)						
Pipe Expansion Rate (%)						
Results of Junction Surface Penetrant Test		Cracks Present	No Cracks	No Cracks	No Cracks	Cracks Present
Tensile Test Results	Tensile Strength (MPa)					
	Break Location	Bonding Boundary	Parent Material	Parent Material	Parent Material	Bonding Boundary
Comprehensive Evaluation						

(0137)

In Comparative Example 4 in which the thickness of the insert material was taken as 200 μm , although the retention time was taken to be 300 seconds, fissures were recognized in the junction in the penetrant test following pipe expansion. Moreover, the tensile strength was 588 MPa, and the specimen broke away from the bonding boundary. This is thought to have been because the elements contained in the insert material were not sufficiently diffused because the insert material was thick, and thus the deformability of the bonding boundary vicinity was diminished.

(0138)

Moreover, in Comparative Example 5 in which the bonding temperature was taken as 1450°C, melting damage occurred in the junction vicinity. Also, fissures were recognized in the junction in the penetrant test following pipe expansion. Furthermore, the tensile strength was 657 MPa, and the specimen broke away from the bonding boundary.

(0139)

In contrast to this, in Embodiments 7, 8, and 9 in which the thickness of the insert material was set below 100 μm and the bonding temperature was set below 1400°C, no melting damage was recognized in any of the junctions, and no fissures were recognized on the bonding boundary in the penetrant test following pipe expansion for any of the embodiments. Moreover, the bonding strengths all exhibited strengths greater than 700 MPa, which is equivalent to that of the parent material, and the specimens broke away from the parent material side.

(0140)

Also, all of the end diameter expansion rates of the metal pipes were taken to be 15% in Embodiments 7 - 9 and Comparative Examples 4 - 5, so all of the maximum level differences were 0.5 mm.

(0141)

From the above results, it became clear that if the width of the insert material is set to 100 μm in the case in which metal pipes are liquid phase diffusion bonded, then fissures will not generate on the junction following pipe expansion and metal pipe joints with high bond strength can be obtained. Moreover, it also became clear that it is necessary to set the bonding temperature to less than 1400°C in order to suppress melting damage of the junction.

(0142)

(Embodiment 10)

Pipe expansion was performed on a metal pipe joint using method A. A carbon steel pipe made from API H40 with an external diameter of 7 inches (178 mm) and wall thickness 0.231 inches (6 mm) was used for the metal pipe, and the end internal diameter of this steel pipe was expanded such that the end diameter expansion rate was 15%.

(0143)

Next, the end face of the expanded metal pipe was finished such that the surface roughness R_{max} is less than $30 \mu\text{m}$, a Ni-family alloy foil with a melting point of 1140°C and thickness of $40 \mu\text{m}$ that has a composition equivalent to JIS BNi-5 was placed on the bonding boundary of the metal pipe, and liquid phase diffusion bonding was performed. Furthermore, the obtained metal pipe joint was expanded using a mandrel such that the pipe expansion rate was 25%.

(0144)

Also, a high frequency induction heating method that uses a high frequency current with a frequency of 3 kHz was used as the heating method for the junction. Moreover, the bonding conditions were such that the bonding temperature was 1400°C , the retention time was 30 seconds, and the applied pressure was 5 MPa, and bonding was performed in an Ar atmosphere.

(0145)

(Embodiment 11)

Apart from setting the retention time at the bonding temperature to 300 seconds and the applied pressure to 1.5 MPa, the manufacturing and expansion of the metal pipe joint were performed in accordance with the same procedures as with Embodiment 10.

(0146)

(Comparative Example 6)

Apart from setting the retention time at the bonding temperature to 15 seconds, the manufacturing and expansion of the metal pipe joint were performed in accordance with the same procedures as with Embodiment 10.

(0147)

(Comparative Example 7)

A Ni-family alloy foil with thickness of $30 \mu\text{m}$ that has a composition equivalent to JIS BNi-5 was used as an insert material, and apart from setting the retention time at the bonding temperature to 300 seconds and the applied pressure to 1 MPa, the manufacturing and expansion of the metal pipe joint were performed in accordance with the same procedures as with Embodiment 10.

(0148)

(Comparative Example 8)

Apart from setting the bonding temperature to 1250°C , the retention time to 300 seconds, and the applied pressure to 7 MPa, the manufacturing and expansion of the metal pipe joint were performed in accordance with the same procedures as with Embodiment 10.

(0149)

With respect to the metal pipe joints that were obtained in Embodiments 10 - 11 and Comparative Examples 6 - 8, maximum level difference tests, penetrant tests, and tensile tests were conducted in accordance with the same procedures as with Embodiment 1. The results are shown in Table 4.

(0150)

(Table 4)

[see source for numbers and English]

Test Number		Comparative Example 6	Embodiment 10	Comparative Example 7	Embodiment 11	Comparative Example 8
Steel Pipe	Material					
	Dimensions	External Diameter (Inches)				
		Wall Thickness (Inches)				
End Diameter Expansion Rate (%)						
Bonding Surface Roughness (Rmax: μm)						
Insert Material	Material					
	Melting Point ($^{\circ}\text{C}$)					
	Thickness (μm)					
	Form		Foil	Foil	Foil	Foil
Bonding Temperature ($^{\circ}\text{C}$)						
Retention Time (s)						
Applied Pressure (MPa)						
Bonding Atmosphere						
Heating Method for the Junction		High Frequency Induction Heating Method (3 kHz)	High Frequency Induction Heating Method (3 kHz)	High Frequency Induction Heating Method (3 kHz)	High Frequency Induction Heating Method (3 kHz)	High Frequency Induction Heating Method (3 kHz)
Maximum Level Difference of the Junction (mm)						
Pipe Expansion Rate (%)						
Results of Junction Surface Penetrant Test		Cracks Present	No Cracks	Cracks Present	No Cracks	Cracks Present
Tensile Test Results	Tensile Strength (MPa)					
	Break Location	Bonding Boundary	Parent Material	Bonding Boundary	Parent Material	Bonding Boundary
Comprehensive Evaluation						

(0151)

In Comparative Example 6 in which the retention time at the bonding temperature was taken as 15 seconds, fissures were recognized in the junction in the penetrant test following pipe expansion. Moreover, the tensile strength was 563 MPa, and the specimen broke away from the bonding boundary. This is thought to have been because the diffusion of elements was not sufficiently performed because the retention time was short, and thus the deformability of the bonding boundary vicinity was diminished.

(0152)

Moreover, in Comparative Example 7 in which the applied pressure was taken as 1 MPa, although the retention time at the bonding temperature was taken as 300 seconds, fissures were recognized in the

junction in the penetrant test following pipe expansion. Also, the tensile strength was 628 MPa, and the specimen broke away from the bonding boundary. This is thought to have been because the bonding boundary did not sufficiently adhere and partially unbonded portions generated because the applied pressure was low, and therefore the deformability of the entire bonding boundary was diminished.

(0153)

Furthermore, in Comparative Example 8 in which the applied pressure was taken as 7 MPa, although the bonding temperature was reduced to 1250°C, excessive deformation occurred in the junction vicinity. Moreover, fissures were recognized in the junction in the penetrant test following pipe expansion. Furthermore, the tensile strength was 687 MPa, and the specimen broke away from the bonding boundary.

(0154)

In contrast to this, in Embodiment 10 in which the applied pressure was set to 5 MPa and the retention time was set to 30 seconds, and in Embodiment 11 in which the applied pressure was set to 1.5 MPa and the retention time was set to 300 seconds, no fissures were recognized on the bonding boundary in the penetrant test following pipe expansion for either of the embodiments. Moreover, the bonding strengths both exhibited strengths greater than 700 MPa, which is equivalent to that of the parent material, and the specimens broke away from the parent material side.

(0155)

Also, all of the end diameter expansion rates of the metal pipes were taken to be 15% in Embodiments 10 - 11 and Comparative Examples 6 - 8, so all of the maximum level differences were 0.5 mm.

(0156)

From the above results, it became clear that if the applied pressure is set greater than 1.5 MPa and less than 5 MPa in the case in which metal pipes are liquid phase diffusion bonded, then fissures will not generate on the junction following pipe expansion and metal pipe joints with high bond strength can be obtained.

(0157)

(Embodiment 12)

Pipe expansion was performed on a metal pipe joint using method A. A steel pipe was used with an external diameter of 10.75 inches (269 mm) and wall thickness 0.5 inches (13 mm) made from American Petroleum Institution Grade LC52-1200 (called "LC52-1200" hereafter), which is a type of martensitic stainless steel, and the end internal diameter of this steel pipe was expanded such that the end diameter expansion rate was 15%.

(0158)

Next, the end face of the expanded steel pipe was finished such that the surface roughness R_{max} is less than 50 μm , a Ni-family alloy foil with melting point of 1140°C and thickness of 40 μm that has a composition equivalent to JIS BNi-5 was placed on the bonding boundary of the metal pipe, and liquid phase diffusion bonding was performed. Furthermore, the obtained metal pipe joint was expanded using a mandrel such that the pipe expansion rate was 25%.

(0159)

Also, a high frequency induction heating method that uses a high frequency current with a frequency of 3 kHz was used as the heating method for the junction. Moreover, the bonding conditions were such that the bonding temperature was 1300°C, the retention time was 120 seconds, and the applied pressure was 4 MPa, and bonding was performed in an Ar atmosphere.

(0160)

(Embodiment 13)

Apart from setting the bonding temperature to 1350°C, the retention time to 210 seconds, the applied pressure to 3.5 MPa, and the frequency of the high frequency current that flows through the induction coil to 100 kHz, the manufacturing and expansion of the metal pipe joint were performed in accordance with the same procedures as with Embodiment 12.

(0161)

(Embodiment 14)

Apart from setting the bonding temperature to 1350°C, the retention time to 210 seconds, the applied pressure to 3.5 MPa, and performing bonding with a high frequency direct conduction heating method that uses a high frequency current with frequency of 25 kHz, the manufacturing and expansion of the metal pipe joint were performed in accordance with the same procedures as with Embodiment 12.

(0162)

(Comparative Example 9)

Apart from setting the surface roughness R_{max} of the bonding surface to 100 μm , the bonding temperature to 1400°C, and the retention time to 300 seconds, the manufacturing and expansion of the metal pipe joint were performed in accordance with the same procedures as with Embodiment 12.

(0163)

(Comparative Example 10)

Apart from setting the retention time at the bonding temperature to 300 seconds, the applied pressure to 5 MPa, and the frequency of the high frequency current that flows through the induction coil to 400 kHz, the

manufacturing and expansion of the metal pipe joint were performed in accordance with the same procedures as with Embodiment 12.

(0164)

With respect to the metal pipe joints that were obtained in Embodiments 12 - 14 and Comparative Examples 9 - 10, maximum level difference tests, penetrant tests, and tensile tests were conducted in accordance with the same procedures as with Embodiment 1. The results are shown in Table 5.

(0165)

(Table 5)

[see source for numbers and English]

Test Number		Comparative Example 9	Embodiment 12	Comparative Example 10	Embodiment 13	Embodiment 14
Steel Pipe	Material					
	Dimensions	External Diameter (Inches)				
		Wall Thickness (Inches)				
End Diameter Expansion Rate (%)						
Bonding Surface Roughness (Rmax: μm)						
Insert Material	Material					
	Melting Point ($^{\circ}\text{C}$)					
	Thickness (μm)					
	Form		Foil	Foil	Foil	Foil
Bonding Temperature ($^{\circ}\text{C}$)						
Retention Time (s)						
Applied Pressure (MPa)						
Bonding Atmosphere						
Heating Method for the Junction		High Frequency Induction Heating Method (3 kHz)	High Frequency Induction Heating Method (3 kHz)	High Frequency Induction Heating Method (400 kHz)	High Frequency Induction Heating Method (100 kHz)	High Frequency Induction Heating Method (25 kHz)
Maximum Level Difference of the Junction (mm)						
Pipe Expansion Rate (%)						
Results of Junction Surface Penetrant Test		Cracks Present	No Cracks	Cracks Present	No Cracks	No Cracks
Tensile Test Results	Tensile Strength (MPa)					
	Break Location	Bonding Boundary	Parent Material	Bonding Boundary	Parent Material	Parent Material
Comprehensive Evaluation						

(0166)

In Comparative Example 9 in which the surface roughness Rmax of the bonding boundary was set to 100 μm , although diffusion bonding was performed under conditions of relatively high temperature, high pressure, and long time, fissures were recognized in the junction in the penetrant test following pipe expansion. Moreover, the tensile strength was 477 MPa, and the specimen broke away from the bonding boundary. This is thought to have been because it was not possible to fill with melted Ni alloy the irregularities that were present on the bonding boundary because the surface texture was rough, and therefore the deformability of the entire bonding boundary was diminished.

(0167)

Likewise, in Comparative Example 10 in which induction heating was performed using a high frequency current with a frequency of 400 MPa [sic], although diffusion bonding was performed under conditions of relatively high temperature, high pressure, and long time, fissures were recognized in the junction in the penetrant test following pipe expansion. Moreover, the tensile strength was 431 MPa, and the specimen broke away from the bonding boundary. This is thought to have been because the entire bonding boundary did not heat uniformly and unbonded portions generated on the inner periphery side of the metal pipe because the frequency was high, and therefore the deformability of the entire bonding boundary was diminished.

(0168)

In contrast to this, in Embodiments 12 - 14 in which the surface roughness R_{max} of the bonding boundary was set to 50 μm and a high frequency current with a frequency less than 100 kHz was used, no fissures were recognized on the bonding boundary in the penetrant test following pipe expansion for any of the embodiments. Moreover, the bonding strengths all exhibited strengths greater than 700 MPa, which is equivalent to that of the parent material, and the specimens broke away from the parent material side.

(0169)

Also, all of the end diameter expansion rates of the metal pipes were taken to be 15% in Embodiments 12 - 14 and Comparative Examples 9 - 10, so all of the maximum level differences were 0.5 mm.

(0170)

From the above results, it became clear that if the surface roughness R_{max} of the bonding boundary is set to 50 μm in the case in which metal pipes are liquid phase diffusion bonded, then fissures will not generate on the junction following pipe expansion and metal pipe joints with high bond strength can be obtained. Moreover, it became clear that if the frequency of the high frequency current is set below 100 kHz in the case in which the bonding boundary is heated through high frequency induction heating or high frequency direct conduction heating, it is possible to restrain the reduction of deformability that originates from the generation of unbonded portions.

(0171)

(Embodiment 15)

Pipe expansion was performed on a metal pipe joint using method B. A carbon steel pipe made from API 40H with an external diameter of 7 inches (178 mm) and wall thickness 0.231 inches (6 mm) was used for the metal pipe, and the end internal diameter of this steel pipe was expanded such that the end diameter expansion rate was 10%.

(0172)

Next, external thread was established on the end faces of the expanded metal pipes, and like metal pipes were fastened to one another with a coupling that has internal thread that can screw into this external thread. Furthermore, the obtained metal pipe joint was expanded using a mandrel such that the pipe expansion rate was 10%.

(0173)

(Embodiment 16)

Apart from setting the end diameter expansion rate of the metal pipe to 25% and expanding the metal pipe joint with a 25% pipe expansion rate, the manufacturing and expansion of the metal pipe joint were performed in accordance with the same procedures as with Embodiment 15.

(0174)

(Embodiment 16 [sic])

Apart from using as the metal pipe a steel pipe made from LC52-1200 with an external diameter of 10.75 inches (273 mm) and wall thickness 0.5 inches (127 mm), setting the end diameter expansion rate to 25%, and expanding the metal pipe joint with a 25% pipe expansion rate, the manufacturing and expansion of the metal pipe joint were performed in accordance with the same procedures as with Embodiment 15.

(0175)

(Comparative Example 11)

Apart from setting the end diameter expansion rate of the metal pipe to 0%, the manufacturing and expansion of the metal pipe joint were performed in accordance with the same procedures as with Embodiment 15.

(0176)

(Comparative Example 12)

Apart from using as the metal pipe a steel pipe made from LC52-1200 with an external diameter of 10.75 inches (273 mm) and wall thickness 0.5 inches (127 mm), setting the end diameter expansion rate to 15%, and expanding the metal pipe joint with a 25% pipe expansion rate, the manufacturing and expansion of the metal pipe joint were performed in accordance with the same procedures as with Embodiment 15.

(0177)

Hydraulic pressure tests were conducted with respect to each of the metal pipe joints that were obtained in Embodiments 15 - 17 and Comparative Examples 11 - 12. The results are shown in Table 6.

(0178)

(Table 6)

[see source for numbers and English]

Test Number		Comparative Example 11	Embodiment 15	Embodiment 16	Embodiment 17	Comparative Example 12
Steel Pipe	Material					
	Dimensions	External Diameter (Inches)				
		Wall Thickness (Inches)				
End Diameter Expansion Rate (%)						
Pipe Expansion Rate (%)						
Hydraulic Pressure Test Pressure (psi)						
Hydraulic Pressure Test Results		Leak Generation	Satisfactory	Satisfactory	Satisfactory	Leak Generation
Comprehensive Evaluation						

(0179)

With respect to Comparative Example 11 in which the end diameter expansion rate was set to 0% and the metal pipe joint was expanded with a 10% pipe expansion rate, water leaks generated from the junction after having performed a hydraulic pressure test with 2100 psi pressure.

(0180)

In contrast to this, in Embodiment 15 in which both the end diameter expansion rate and the pipe expansion rate were set to 10%, and in Embodiment 16 in which both the end diameter expansion rate and the pipe expansion rate were set to 25%, water leaks did not generate from either of the junctions even when hydraulic pressure tests were performed with 2100 psi pressure.

(0181)

Moreover, with respect to Comparative Example 12 in which the end diameter expansion rate was set to 15% and the metal pipe joint was expanded with a 20% pipe expansion rate, water leaks generated from the junction after having performed a hydraulic pressure test with 3000 psi pressure.

(0182)

In contrast to this, in Embodiment 17 in which both the end diameter expansion rate and the pipe expansion rate were set to 25%, water leaks did not generate from the junction even when a hydraulic pressure test was performed with 3000 psi pressure, and a satisfactory metal pipe joint was obtained.

(0183)

From the above results, it became clear that, in the case in which a metal pipe joint that was bonded with a threaded connection method is expanded, if pipe expansion is performed with a pipe expansion rate that is less than the end diameter expansion rate, a metal pipe joint that is superior with respect to airtightness can be obtained.

(0184)

(Embodiment 18)

Pipe expansion was performed on a metal pipe joint using method C. A steel pipe made from STKM12B (JIS G3445) with an external diameter of 140 mm and wall thickness of 7 mm was used for the metal pipe. The end face of this steel pipe was finished such that the surface roughness R_{max} is less than 30 μm , a Ni-family alloy foil with a melting point of 1050°C and thickness of 50 μm that has a composition equivalent to JIS BNi-3 was placed on the bonding boundary, and diffusion bonding was performed. Furthermore, the

obtained metal pipe joint was expanded with a mandrel such that the pipe expansion rate was between 5 - 25%.

(0185)

Also, a high frequency induction heating method that used a high frequency current with a frequency of 3 kHz was used as the heating method for the junction, and two types of coils were used for the heating coils - a coil in which the heating width is 20 mm, and a coil in which the heating width is 40 mm.

Moreover, as for the bonding conditions, the bonding temperature was set between 1250 - 1350°C, the retention time was set between 60 - 300 seconds, the applied pressure was set between 1 - 4 MPa, and bonding was performed within an Ar atmosphere. Furthermore, the lateral expansion rate was adjusted by modifying the bonding conditions.

(0186)

The lateral expansion rates and expansion lengths of the obtained metal pipe joints and the presence of cracks and tensile strengths following pipe expansion are shown in Table 7. Also, the tensile strengths (noted as "parent material" in Table 7) of the non-conjugative regions of the metal pipes that were expanded with prescribed pipe expansion rates are also included in Table 7.

(0187)

(Table 7)

[see source for numbers and English]

Test Number	Bonding Conditions		Lateral Expansion Rate (%)	Heating Width (mm)	Expansion Length (mm)	Tensile Strength Before Expansion (MPa)	Junction Expansion Test Results									
	Bonding Temperature (°C)	Retention Time (s)					Applied Pressure (MPa)	Pipe Expansion Rate 5%		Pipe Expansion Rate 10%		Pipe Expansion Rate 15%		Pipe Expansion Rate 20%		Pipe Expansion Rate 25%
							Crack Presence	Tensile Strength (MPa)	Crack Presence	Tensile Strength (MPa)	Crack Presence	Tensile Strength (MPa)	Crack Presence	Tensile Strength (MPa)	Crack Presence	Tensile Strength (MPa)
							None		Present		Present		Present		Present	
							None		Present		Present		Present		Present	
							None		None		None		None		None	
							None		None		None		None		None	
							None		None		None		None		None	
							None		None		None		None		None	
							None		None		None		None		None	
							None		None		None		None		None	
							None		None		None		None		None	
							None		None		None		None		None	
							None		None		None		None		None	
							None		None		None		None		None	
							None		None		None		None		None	
							None		None		None		None		None	
Parent Material							None		None		None		None		None	

(0188)

It can be seen from Table 7 that the expansion length becomes longer as a heating coil with a long heating width is used. In other words, it can be seen that the expansion length becomes 40 - 50 mm if the heating width is set to 20 mm, and the expansion length becomes 80 - 90 mm if the heating width is set to 40 mm.

(0189)

Moreover, it can be seen from Table 7 that, in the case in which the expansion length is set between 40 - 50 mm, a metal pipe joint is obtained in which pipe expansion can be performed with a larger pipe expansion rate as the lateral expansion rate becomes larger.

(0190)

Stated simply, in the case in which the lateral expansion rate is 1.00, cracks already generated on the bonding boundary when the pipe expansion rate was 10%, and a sound metal pipe joint was not obtained (Test Number 1). When the lateral expansion rate was set to 1.02, a sound metal pipe joint was obtained in the case in which the pipe expansion rate was less than 15%, but fissures generated in the junction when the pipe expansion rate was greater than 20% (Test Number 3).

(0191)

In contrast to this, when the lateral expansion rate was set greater than 1.04 (Test Numbers 5, 7, 9, and 11), no fissures generated in the junctions even when the pipe expansion rate was set to 20%, and sound metal pipe joints that have strengths equivalent to the parent material were obtained.

(0192)

The case in which the expansion length was set between 80 - 90 mm was the same, and it can be seen that a metal pipe joint is obtained in which pipe expansion can be performed with a larger pipe expansion rate as the lateral expansion rate becomes larger (Test Numbers 2, 4, 6, 8, 10).

(0193)

Furthermore, it can be seen from Table 7 that, in the case in which the lateral expansion rate is made to be uniform, there is a tendency for metal pipe joints to be obtained that can withstand pipe expansion with a larger pipe expansion rate as the expansion length becomes longer. In other words, in the case in which the lateral expansion rate was 1.02 and the expansion length was 40 mm, fissures generated in the junction when pipe expansion was performed with a pipe expansion rate of 20% (Test Number 3). On the other hand, in the case in which the expansion length was set to 80 mm, no fissures generated in the joint even when pipe expansion was performed with a pipe expansion rate of 20%, and a sound joint that has strength equivalent to the parent material was obtained (Test Number 4).

(0194)

Likewise, in the case in which the lateral expansion rate was 1.04 and the expansion length was 45 mm, fissures generated in the junction when pipe expansion was performed with a pipe expansion rate of 25% (Test Number 5). On the other hand, in the case in which the expansion length was set to 90 mm, no fissures generated in the junction even when pipe expansion was performed with a pipe expansion rate of 25%, and a sound joint that has the strength equivalent to the parent material was obtained (Test Number 6).

(0195)

From the above results, it became clear that if metal pipes whose ends have not been expanded are butted and the bonding boundary vicinity is deformed into a barrel shape with a prescribed lateral expansion rate at the time of diffusion bonding, then fissures will not generate in the junction even in the case in which pipe expansion is performed with a high pipe expansion rate, and a sound metal pipe joint with high bonding strength can be obtained.

(0196)

(Embodiment 19)

Pipe expansion was performed on a metal pipe joint using method A'. A carbon steel pipe made from API H40 with an external diameter of 7 inches (178 mm) and wall thickness 0.231 inches (6 mm) was used for the metal pipe, and the end internal diameter of this steel pipe was expanded such that the end diameter expansion rate was 5%.

(0197)

Next, grooves were formed on the end faces of the expanded metal pipes, and the metal pipes were welded with a gas shield arc welding method. Furthermore, the obtained metal pipe joint was expanded using a mandrel such that the pipe expansion rate was 25%.

(0198)

Also, welding was performed using JIS YGW21 ($\text{\O}1.2$ mm) as the welding wire and a mixed gas of Ar + 20%CO₂ as the shield gas, with a 280A welding current.

(0199)

(Embodiments 20 - 21, Comparative Examples 13 - 14)

Apart from respectively setting the end diameter expansion rates of metal pipes 30 to 0% (Comparative Example 13), 3% (Comparative Example 14), 10% (Embodiment 20), and 15% (Embodiment 21), the manufacturing and expansion of the metal pipe joints were performed in accordance with the same procedures as with Embodiment 19.

(0200)

With respect to the metal pipe joints that were obtained in Embodiments 19 - 21 and Comparative Examples 13 - 14, penetrant tests and tensile tests were performed in accordance with the same procedures as with Embodiment 1. The results are shown in Table 8.

(0201)

(Table 8)

[see source for numbers and English]

Test Number		Comparative Example 13	Comparative Example 14	Embodiment 19	Embodiment 20	Embodiment 21
Steel Pipe	Material					
	Dimensions	External Diameter (Inches)				
		Wall Thickness (Inches)				
End Diameter Expansion Rate (%)						
Welding Method		Gas Shield Arc Welding Method Welding Wire: JIS YGW21 ($\text{\O}1.2$ mm) Shield Gas: Ar + 20%CO ₂ Welding Current: 280A				
Pipe Expansion Rate (%)						
Results of Junction Surface Penetrant Test		Cracks Present	Cracks Present	No Cracks	No Cracks	No Cracks

Tensile Test Results	Tensile Strength (MPa)					
	Break Location	Welded Section	Welded Section	Parent Material	Parent Material	Parent Material
Comprehensive Evaluation						

(0202)

In Comparative Example 13 in which the end diameter expansion rate was set to 0%, multiple fissures were recognized in the junction in the penetrant test following pipe expansion. Furthermore, the tensile strength exhibited low strength of 317 MPa, and the specimen broke away from the welded section.

(0203)

Likewise, in Comparative Example 14 in which the end diameter expansion rate was set to 3%, significant fissures were recognized in the junction in the penetrant test following pipe expansion, but the number of fissures was less than in Comparative Example 13. Accordingly, the tensile strength improved to 495 MPa, but the specimen broke away from the welded section.

(0204)

In contrast to this, in Embodiments 19, 20, and 21 in which the end diameter expansion rates were respectively set to 5%, 10%, and 15%, no fissures were recognized on the bonding boundary in the penetrant tests following pipe expansion in any of the embodiments. Furthermore, the bonding strengths all exhibited strengths greater than 700 MPa, which is equivalent to that of the parent material, and the specimens broke away from the parent material side.

(0205)

From the above results, it became clear that if the end internal diameter of the metal pipe is expanded before the metal pipes are welded such that a value greater than the prescribed end diameter expansion rate is achieved, it becomes more difficult for fissures to generate on the junction at the time of pipe expansion as the end diameter expansion rate becomes larger, and a metal pipe joint with higher bonding strength can be obtained.

(0206)

The embodiments of the present invention were described in detail above, but the present invention is in no way limited to the embodiments described above, and various alterations are possible within a scope that does not deviate from the purport of the present invention.

(0207)

For example, there are no particular restrictions regarding the shape of the mandrel that is used for pipe expansion, and it would be acceptable to use a tapered mandrel or a mandrel that has a roller on the tapered surface.

(0208)

Moreover, there are also no particular restrictions regarding the drive means for the mandrel. For example, it would be acceptable to affix a shaft to the base surface of the mandrel, and then drive the mandrel into the metal pipe joint using that shaft.

Alternatively, it would also be acceptable to apply hydraulic pressure to the base surface of the mandrel, and then move it through the metal pipe joint from one end to the other with hydraulic pressure.

(0209)

Moreover, in the embodiments described above, a diffusion bonding method, a threaded connection method, or a welding method was used to bond metal pipe joints in which the internal diameter of the junction has become larger than the internal diameter of the non-conjugative regions, but the bonding method of the metal pipes joints is not limited to these methods. For example, it would also be acceptable to form a metal pipe joint by bonding metal pipes with a friction pressure welding method.

(0210)

Furthermore, the metal pipe joint for pipe expansion and its manufacturing method of the present invention are particularly suited for oil well pipes for casing that is buried beneath the earth and the manufacturing method thereof, but the applications of the present invention are not limited to oil well pipes, and it is possible to use them as casing that is used in natural gas wells, geothermal wells, hot spring wells, and water wells, or as line pipe that is laid on the ground surface or as plumbing for plants and the manufacturing methods thereof. By doing so, it is possible to obtain effects equivalent to those of the embodiments above.

(0211)

(Effects of the Invention)

The metal pipe joint for pipe expansion and its manufacturing method of the present invention uses an industrial tool such as a mandrel to expand a metal pipe joint in which the internal diameter of the junction has become larger than the internal diameter of the non-conjugative regions, so the deformation resistance when expanding the metal pipe joint becomes small. Therefore, it is possible to perform the pipe expansion operation smoothly, and there is the effect that motive energy of the pipe expansion operation is also conserved.

(0212)

Moreover, if the diameter of the end of the metal pipe is expanded in advance with a prescribed end diameter expansion rate and such metal pipes are butted and diffusion bonded or welded, then it is possible to easily obtain a metal pipe joint in which the internal diameter of the junction has become larger than the internal diameter of the non-conjugative regions.

(0213)

Furthermore, in the case in which such a metal pipe joint is expanded, it is possible to make the plastic stress of the junction small in comparison to the plastic stress of the non-conjugative regions. Therefore, even in the case in which heat-affected regions generate at the time of diffusion bonding or welding and the deformability of the junction vicinity is diminished, there is the effect that it becomes difficult for fissures to generate on the junction, and a metal pipe joint that is superior with respect to strength and airtightness can be obtained.

(0214)

Moreover, if metal pipes whose end internal diameters have been expanded with a prescribed end diameter expansion rate are bonded with a threaded connection method to form a metal pipe joint, there is the effect that the thread portions do not plastic-deform, so there is no decrease in airtightness that originates from loose thread.

(0215)

Moreover, even in the case in which like metal pipes whose ends have not been expanded are butted and the junction is deformed into a barrel shape with a prescribed lateral expansion rate at the same time that the metal pipes are diffuse bonded, it is possible to easily obtain a metal pipe joint in which the internal diameter of the junction has become larger than the internal diameter of the non-conjugative regions.

Therefore, if such a metal pipe joint is expanded with a prescribed pipe expansion rate, there is the effect that a metal pipe joint that is superior with respect to strength and airtightness can be obtained.

(0216)

Furthermore, in the case in which the ends of metal pipes are expanded in advance with a prescribed end diameter expansion rate and such metal pipes are butted and diffusion bonded, it is possible to reduce the level differences that generate on the inner periphery side of the junction, even if there is variation in the dimensions of each metal pipe. Therefore, even if pipe expansion is performed, there is no danger of the generation of fissures that originate from stress concentration, so there is the effect that a metal pipe joint that is superior with respect to strength, fatigue characteristics, and corrosion resistance can be obtained.

(0217)

As described above, through the metal pipe joint for pipe expansion and its manufacturing method, it is possible to easily obtain a metal pipe joint in which the energy expenditure required for pipe expansion is small, airtightness and strength are superior, and the level differences that generate in the junction are small. Therefore, if this is applied to an oil well pipe or line pipe, for example, it will contribute to significant cost reduction and reliability improvement in the oil drilling operation or pipe laying operation, and the present invention is an invention in which these effects are extremely large industrially.

(Brief Description of the Drawings)

(Figure 1)

A flow chart that shows the metal pipe joint for pipe expansion and its manufacturing method of the first embodiment of the present invention.

(Figure 2)

A flow chart that shows the pipe expansion method of the metal pipe joint for pipe expansion shown in Figure 1 (d).

(Figure 3)

A flow chart that shows the metal pipe joint for pipe expansion and its manufacturing method of the second embodiment of the present invention.

(Figure 4)

A flow chart that shows the pipe expansion method of the metal pipe joint for pipe expansion shown in Figure 2 (d).

(Figure 5)

Figure 5 (a) - (c) is a flow chart that shows metal pipe joint for pipe expansion and its manufacturing method of the third embodiment of the present invention, and Figure 5 (d) is a figure that shows the expansion method of the metal pipe for pipe expansion shown in Figure 5 (c).

(Figure 6)

A cross sectional diagram that shows the typical structure of an oil well.

(Figure 7)

A cross sectional diagram that shows the threaded connection method (mechanical coupling method).

(Explanation of Symbols)

30, 40, 50	Metal Pipes
32, 42, 52	Metal Pipe Joints
34	Mandrel

[see source for drawings]

(Figure 1)

(c)

Machine work

Machine work

(Figure 3)

(Figure 2)

Applied pressure

(Figure 6)

(Figure 4)
Applied pressure

(Figure 7)

(Figure 5)
(b)
Applied pressure Applied pressure

Continued from the front page:

(51) Int. Cl. ⁷	Identification No.	FI	Theme Code (Reference)
// E 21 B 17/08		E 21 B 17/08	

(25) Japanese Unexamined Patent Application 2000-107870

(72) Inventor: Shigeyuki Inagaki
Aichi-ken, Nagoya-shi, Minami-ku, Tenpaku-cho, 3-9-111
Daido Steel Tenpaku Manor 205

F-Term (Reference)
[see source for numbers and English]



AFFIDAVIT OF ACCURACY

I, Kim Stewart, hereby certify that the following is, to the best of my knowledge and belief, true and accurate translations performed by professional translators of the following patents/abstracts from Japanese to English:

Patent 64-75715
Patent 2000-94068
Patent 2000-107870

Kim Stewart
TransPerfect Translations, Inc.
3600 One Houston Center
1221 McKinney
Houston, TX 77010

- ATLANTA
- BOSTON
- BRUSSELS
- CHICAGO
- DALLAS
- FRANKFURT
- HOUSTON
- LONDON
- LOS ANGELES
- MIAMI
- MINNEAPOLIS
- NEW YORK
- PARIS
- PHILADELPHIA
- SAN DIEGO
- SAN FRANCISCO
- SEATTLE
- WASHINGTON, DC

Sworn to before me this
26th day of February 2002.

Signature, Notary Public

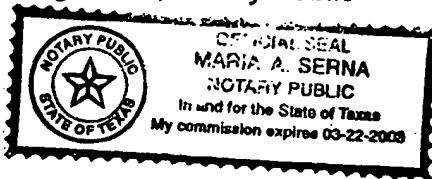

Stamp, Notary Public

Harris County
Houston, TX